

A CELLULAR MECHANISM OF CLASSICAL CONDITIONING IN *APLYSIA*

By R. D. HAWKINS

*Center for Neurobiology and Behavior, College of Physicians and
Surgeons, Columbia University and The New York State Psychiatric
Institute, New York, NY 10032 U.S.A.*

SUMMARY

The defensive siphon and gill withdrawal of *Aplysia* is a simple reflex, mediated by a well-defined neural circuit, that exhibits sensitization in response to strong stimulation of the tail. The siphon withdrawal reflex also exhibits classical conditioning when a weak stimulus to the siphon or mantle shelf (the conditioned stimulus or CS) is paired with a shock to the tail (the unconditioned stimulus or US). Cellular studies indicate that the mechanism of this conditioning shares aspects of the mechanism of sensitization of the reflex: presynaptic facilitation due to a cAMP-mediated decrease in K^+ current and consequent broadening of action potentials in the sensory neurones. Thus, tail shock (the US) produces greater facilitation of the monosynaptic EPSP from a sensory to a motor neurone if the shock is immediately preceded by spike activity in the sensory neurone than if it occurs without spike activity (sensitization), or if the shock and spike activity are presented in a specifically unpaired pattern. This activity-dependent amplification of facilitation involves a greater broadening of action potentials in paired than in unpaired sensory neurones and appears to be due to a greater depression of the same serotonin- and cAMP-sensitive K^+ current involved in sensitization.

These results indicate that a mechanism of classical conditioning of the withdrawal reflex is an elaboration of the mechanism underlying sensitization. By analogy, the mechanisms of higher-order features of learning, such as the effect of contingency, may be built from combinations of the molecular mechanisms of these simple forms of learning.

INTRODUCTION

Learning has been of interest to neuroscientists since the turn of the century (Cajal, 1911). Nonetheless, progress in understanding its neural basis has been limited, primarily because of the immense complexity of the brain. To reduce this complexity to manageable proportions, many modern neuroscientists have adopted a simple systems approach. This involves either: (1) studying learning of reflex behaviours with relatively simple neural circuits in vertebrates (Spencer, Thompson & Nielson, 1966; Cohen, 1969; Woody & Brozek, 1969; Thompson *et al.* 1976), or (2) investigation of learning in animals with relatively simple nervous systems, such as the higher

invertebrates (Horridge, 1962; Krasne, 1969; Pinsker, Kupfermann, Castellucci & Kandel, 1970; Zucker, 1972; Quinn, Harris & Benzer, 1974; Mpitsos & Collins, 1975; Gelperin, 1975; Crow & Alkon, 1978; Walters, Carew & Kandel, 1979; Carew, Walters & Kandel, 1981; Lukowiak & Sahley, 1981). My colleagues and I have taken the second approach in investigating learning in a marine mollusc, *Aplysia californica*. This species possesses a nervous system containing only approximately 10 000 neurones, many of which are unusually large and uniquely identifiable (Frazier *et al.* 1967).

To make progress in understanding the neural basis of learning, it is, however, not sufficient merely to choose a simple preparation. It is also necessary to study relatively simple types of learning such as habituation, sensitization and classical and operant conditioning, which have strict operational definitions. Here I shall review research on two of these elementary forms of learning in *Aplysia*. First, I will briefly summarize the results of research by Kandel and his colleagues on the neural basis of sensitization. Then I will present a more detailed summary of my recent research with Tom Abrams, Tom Carew and Eric Kandel on the neural basis of classical conditioning.

SENSITIZATION OF THE GILL AND SIPHON WITHDRAWAL REFLEX

Studies of learning in *Aplysia* have focused on the defensive withdrawal reflexes of the external organs of the mantle cavity. In *Aplysia* and in other molluscs, the mantle cavity (a respiratory chamber housing the gill) is covered by a protective sheet, the mantle shelf, which terminates in a fleshy spout, the siphon. When the siphon or mantle shelf is touched, they and the gill all contract vigorously and withdraw into the mantle cavity. If the stimulation is repeated at 1-min intervals the evoked response becomes progressively weaker, or habituates (Pinsker *et al.* 1970). If, on the other hand, a noxious stimulus is given to the neck or tail and the siphon is stimulated as before, the evoked response is enhanced or sensitized. A weakly noxious stimulus, such as scratching, produces sensitization lasting for minutes; a stronger stimulus such as an electric shock produces sensitization lasting for hours; repeated electric shocks produce sensitization lasting for days or weeks (Pinsker *et al.* 1970; Pinsker, Hening, Carew & Kandel, 1973; R. D. Hawkins, V. F. Castellucci & E. R. Kandel, unpublished).

Fig. 1 summarizes what is known about the neural basis of short-term (minutes to hours) sensitization of the withdrawal reflex. The reflex is partly monosynaptic: mechanosensory neurones innervating the siphon make direct, excitatory synaptic contacts onto motor neurones innervating the gill and siphon. Habituation of the reflex results from homosynaptic depression of these synapses (Castellucci, Pinsker, Kupfermann & Kandel, 1970). Sensitization, on the other hand, is due, at least in part, to presynaptic facilitation (Castellucci *et al.* 1970; Castellucci & Kandel, 1976). Sensitizing stimuli, such as tail shocks, excite neurones which synapse on or near the terminals of the sensory neurones (Hawkins, Castellucci & Kandel, 1981; Hawkins, 1981a; Bailey, Hawkins, Chen & Kandel, 1981). These neurones are thought to release several transmitters including serotonin or a related amine (Brunelli, Castellucci & Kandel, 1976; Bailey, Hawkins & Chen, 1983; Kistler *et al.* 1983). The

Facilitating transmitter binds to a receptor which is coupled to an adenylyl cyclase in the sensory neurones, so that sensitizing stimulation causes an increase in cAMP levels in the neurones (Bernier, Castellucci, Kandel & Schwartz, 1982). cAMP in turn stimulates a protein kinase, leading to phosphorylation of a protein which is, or is

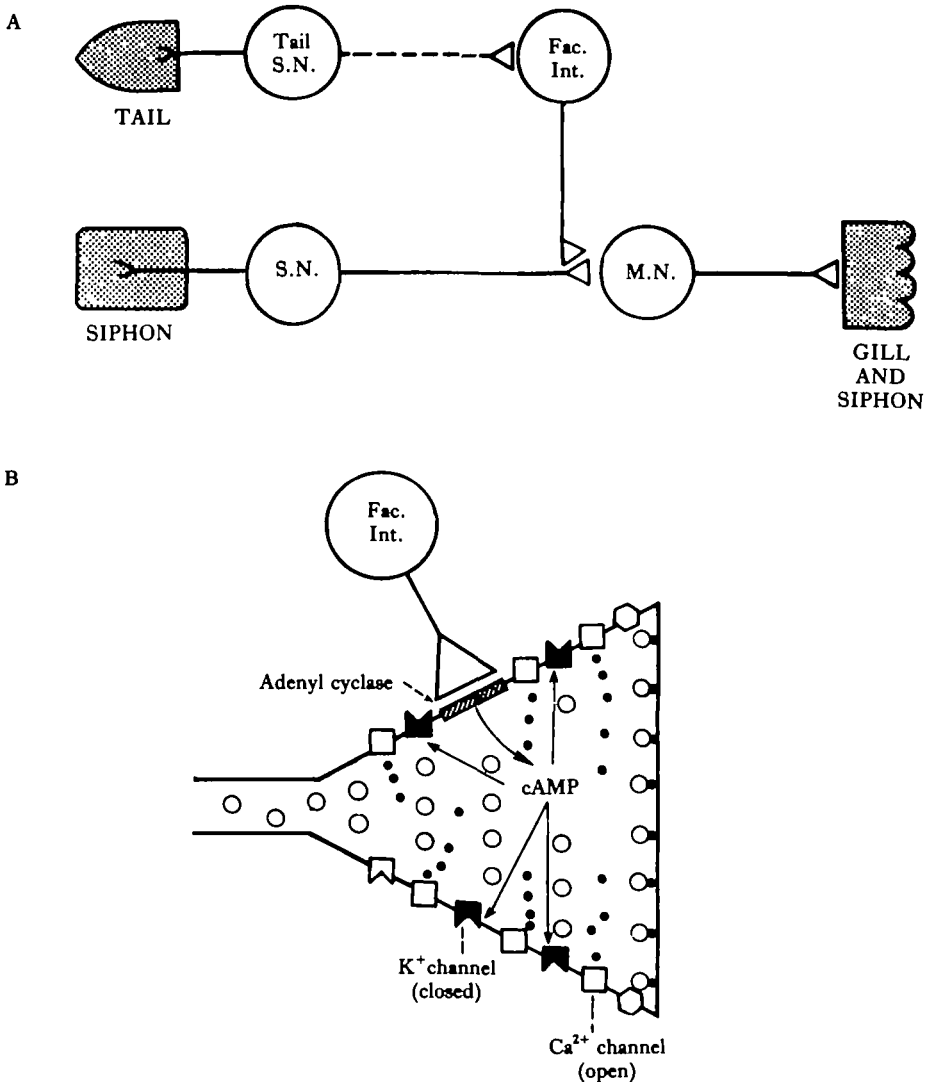

Fig. 1. Neural mechanism of sensitization of the gill and siphon withdrawal reflex. (A) Partial neuronal circuit for the withdrawal reflex and its modification by tail stimulation. Mechanosensory neurones (S.N.) from the siphon make direct excitatory synaptic connections onto gill and siphon motor neurones (M.N.). Tail sensory neurones excite facilitator interneurons (Fac. Int.), which produce presynaptic facilitation of the siphon sensory neurones. (B) Molecular model of presynaptic facilitation underlying sensitization of the withdrawal reflex. Stimulation of the tail produces prolonged inactivation of K⁺ channels in the siphon sensory neurones through a sequence of steps involving cAMP and protein phosphorylation. Closing these K⁺ channels produces broadening of subsequent action potentials, which in turn produces an increase in Ca²⁺ influx and increased transmitter release. (Adapted from Klein & Kandel, 1980.)

associated with, a particular type of K^+ channel (Castellucci *et al.* 1980, 1982; Klein, Camardo & Kandel, 1982). The effect of this phosphorylation is to cause prolonged closure of the channels, so that less K^+ current flows during subsequent action potentials (Klein & Kandel, 1980; Siegelbaum, Camardo & Kandel, 1982). As a result of this reduction in K^+ current, the action potentials have a longer duration, allowing more Ca^{2+} to enter the neurone during the action potential and thus causing more transmitter to be released (Klein & Kandel, 1978; Hawkins, 1981*b*). Increased transmitter release in turn causes a larger postsynaptic potential and more spikes in the motor neurone, and, thus, a larger gill and siphon withdrawal (Kupfermann, Castellucci, Pinsker & Kandel, 1970). Long-term sensitization appears to involve changes at the same locus, since it is accompanied by an increase in the number and size of active zones at sensory neurone synapses (Bailey & Chen, 1983). Kandel & Schwartz (1982) speculate that an increase in cAMP levels may trigger these long-term alterations in the sensory neurones in parallel with the short-term changes.

CLASSICAL CONDITIONING OF THE WITHDRAWAL REFLEX

Classical or Pavlovian conditioning resembles sensitization in that the response to stimulation of one pathway is enhanced by activity in another. Typically, in classical conditioning an initially weak or ineffective conditioned stimulus (CS) becomes effective in producing a behavioural response after it has been paired temporally with a strong unconditioned stimulus (US). What distinguishes conditioning from sensitization is the requirement for temporal pairing of the two stimuli during training. Although there is some debate, it is generally thought that the animal learns that the CS predicts the occurrence of the US, and therefore conditioning can be thought of as a prototype for learning about the predictability of events in the world (Rescorla, 1967, 1968; Kamin, 1969).

Carew *et al.* (1981) found that in addition to undergoing sensitization, the *Aplysia* gill and siphon withdrawal reflex could also undergo classical conditioning. The CS in their experiments was a weak tactile stimulus to the siphon (which initially produced a weak withdrawal response) and the US was an electric shock to the tail. They found that if these two stimuli were temporally paired during training (with the CS slightly preceding the US) there was a much greater enhancement of the response to siphon stimulation than if the two stimuli were given unpaired or randomly in time, or if either stimulus was given alone. This learning was acquired in less than 30 trials, and was retained for at least several days.

More recently, Carew, Hawkins & Kandel (1983) found that the withdrawal reflex could also undergo differential classical conditioning. This paradigm has turned out to be very useful for a neuronal analysis, since it permits each animal to serve as its own control (Fig. 2A). Two conditioned stimuli were used: touching the siphon and stimulation of the mantle. The intensities of these two stimuli were chosen so that they produced approximately equal withdrawal responses before training. Animals were divided into two groups; in one siphon stimulation was paired with tail shock and mantle stimulation was unpaired, while in the other mantle stimulation was paired and siphon stimulation was unpaired (Fig. 2B). The paired stimulus is referred to as the CS^+ and the unpaired stimulus as the CS^- . Both 30 min and 24 h after 15 training

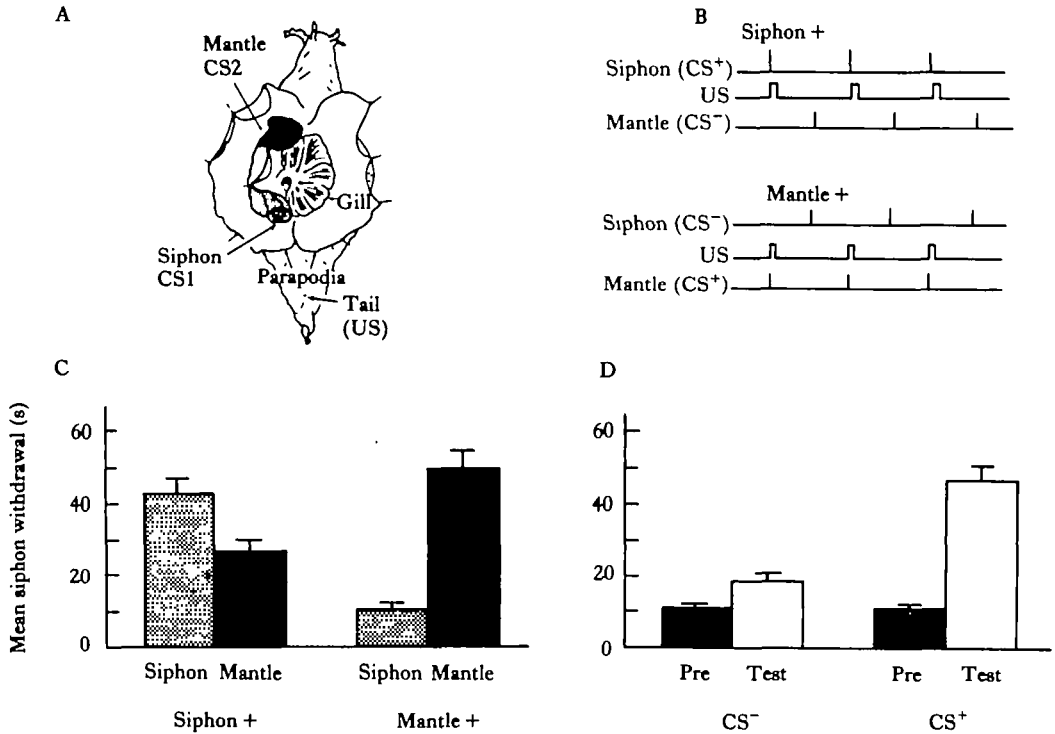

Fig. 2. Differential conditioning of the siphon withdrawal reflex. (A) Dorsal view of *Aplysia* illustrating the two sites used to deliver conditioned stimuli: the siphon (CS1) and mantle shelf (CS2). The unconditioned stimulus (US) was an electric shock delivered to the tail. For illustrative purposes, the parapodia are shown intact and retracted. However, the behavioural studies were all carried out in freely moving animals whose parapodia were surgically removed. (B) Paradigm for differential conditioning: one group (Siphon +) received the siphon CS (CS⁺) paired with the US and the mantle CS (CS⁻) specifically unpaired with the US; the other group (Mantle +) received the mantle stimulus as CS⁺ and the siphon stimulus as CS⁻. The intertrial interval was 5 min. (C) Results of an experiment using the paradigm shown in part B. Testing was carried out 30 min after 15 training trials. The Siphon + group ($N = 12$) showed significantly longer responses ($P < 0.05$) to the siphon CS than to the mantle CS, whereas the Mantle + group ($N = 12$) showed significantly longer responses ($P < 0.01$) to the mantle CS than to the siphon CS. Data in this and all other figures are expressed as means \pm standard error of the mean. (D) Pooled data from C. Test scores from the unpaired (CS⁻) and paired (CS⁺) pathways are compared to the respective pre-test scores for these pathways. The increase in the CS⁺ scores was significantly greater than the increase in the CS⁻ scores ($P < 0.005$), demonstrating that differential conditioning occurred. (Adapted from Carew, Hawkins & Kandel, 1983.)

trials, the response to the CS⁺ was significantly greater than the response to the CS⁻ for the two groups (Fig. 2C). If these test scores are compared to the pre-test scores for each pathway (Fig. 2D), there is some increase in response to the CS⁻, which we attribute to sensitization, and a significantly greater increase in response to the CS⁺. We use the difference in response to the CS⁺ and the CS⁻ as an index of associative learning. In further experiments we obtained significant differential conditioning following a single training trial, and progressively stronger conditioning with an increased number of trials.

In these respects conditioning of the *Aplysia* siphon withdrawal reflex is similar to

many instances of conditioning in vertebrates. To compare further conditioning in these different species we next investigated the effect of the interstimulus interval (ISI) – the time interval between presentation of the CS⁺ and the US during training (Hawkins, Carew & Kandel, 1983*b*). In previous studies the ISI was 0.5 s. This interval was chosen because it approximates to the optimal interval in many instances of vertebrate conditioning (e.g. Gormezano, 1972). Poorer conditioning is often obtained with longer intervals, and little or no conditioning is obtained if the order of the stimuli is reversed (i.e. if the US precedes the CS). To explore the effect of this parameter on conditioning in *Aplysia*, we systematically trained different groups of animals with different interstimulus intervals and measured the degree of conditioning obtained. We again used a differential training procedure, delivering the CS⁻ specifically unpaired with tail shock and varying the time interval between the onsets of the CS⁺ and the US. As before, our measure of associative learning was the difference in responding to the CS⁺ and the CS⁻ following training. We obtained the best conditioning when the onset of the CS⁺ preceded the onset of the US by 0.5 s, less conditioning when the interval was 1.0 s, and no conditioning when the interval was 2, 5 or 10 s, or when the onset of the US preceded the onset of the CS⁺ (that is, no backwards conditioning). When the two stimuli were simultaneous there was a suggestion of learning which was not, however, statistically significant.

In this respect as well, then, conditioning in *Aplysia* is similar to many instances of conditioning in vertebrates. This suggests that basically similar neuronal mechanisms could underlie conditioning in these different species.

A CELLULAR MECHANISM OF CLASSICAL CONDITIONING IN *APLYSIA*

A hypothesis (which was appealing because of its simplicity) was that the neural mechanism of classical conditioning in *Aplysia* might be an elaboration of the neural mechanism of sensitization. As reviewed above, sensitizing stimulation such as tail shock (the US in our conditioning experiments) produces presynaptic facilitation of all of the sensory neurones. We suggested that spike activity in a sensory neurone, just before the US is delivered (as would occur in the paired pathway during behavioural conditioning), might amplify the amount of facilitation which the US produced in that neurone. This mechanism would lead to greater strengthening of the sensory neurone synapses in the paired pathway and a greater response to the paired CS.

We have tested this hypothesis by attempting to produce a neural analogue of classical conditioning in a preparation consisting of the isolated nervous system attached to the tail by its nerves (Hawkins, Abrams, Carew & Kandel, 1983*a*). In these experiments we stimulated individual sensory neurones intracellularly, instead of touching the skin, and recorded the EPSPs in a motor neurone instead of measuring the behavioural response. Otherwise, we tried to keep the experimental protocol as similar as possible to that in the behavioural conditioning experiments, using the same number of trials, inter-trial interval, training-testing interval, and in most experiments even the same US. As in the behavioural experiments, we used a differential conditioning procedure (Fig. 3A). During training, intracellularly produced spike activity in one sensory neurone was paired with the US, while a second sensory neurone had spike activity specifically unpaired with the US, or no spike activity at

US alone' training). The EPSP from each sensory neurone to a motor neurone was measured before and 5 or 15 min after training. In the example shown in Fig. 3B,

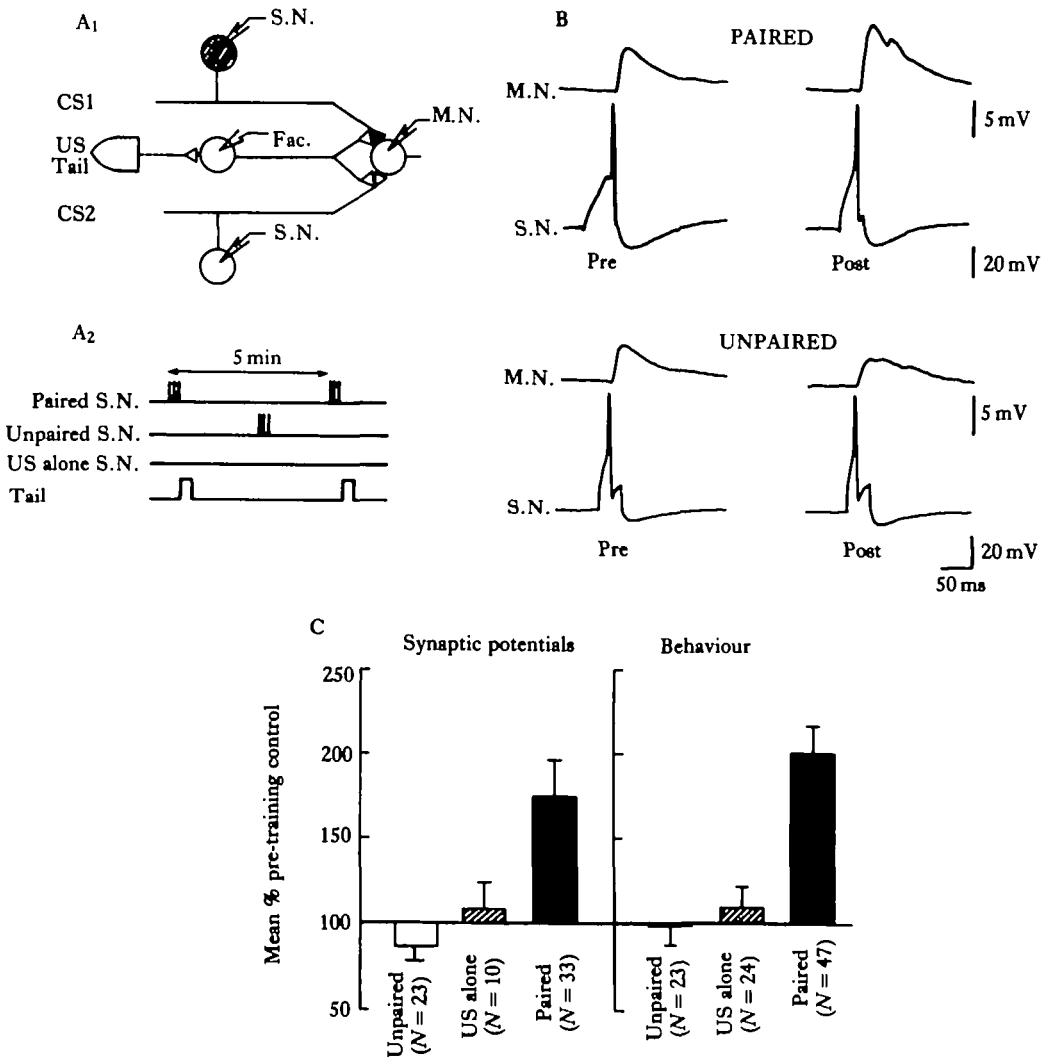

Fig. 3. Activity-dependent facilitation of a monosynaptic EPSP in the neuronal circuit for the withdrawal reflex. (A₁) Experimental arrangement and (A₂) training protocol. Shading indicates that spike activity in the neurone is paired with the US. See text for details. Fac., facilitator interneurone. (B) Examples of the EPSPs produced in a common postsynaptic siphon motor neurone (M.N.) by action potentials in a paired and an unpaired sensory neurone (S.N.) before (Pre) and 1 h after training (Post). Facilitation of the EPSP from the paired sensory neurone was greater than that of the EPSP from the unpaired sensory neurone in the same experiment. (C) Comparison of average cellular data showing differential facilitation of EPSPs and behavioural data showing differential conditioning of the withdrawal reflex. PSP data are pooled from two types of experiments: paired *versus* unpaired (23 experiments) and paired *versus* US alone (10 experiments). Facilitation of the EPSPs from the paired neurones was significantly greater than that of the EPSPs from the control neurones ($P < 0.02$ in both cases). Behavioural data are from experiments on conditioning of the withdrawal reflex with the same protocol and parameters as the cellular experiments. Testing was carried out 15 min after five training trials in both types of experiments. (Adapted from Hawkins, Abrams, Carew & Kandel, 1983a.)

the EPSP from the paired neurone approximately doubled in amplitude as a result of the training, while the EPSP from the unpaired neurone became slightly smaller. In 33 similar experiments facilitation of the EPSPs from the paired sensory neurones was significantly greater than that of the EPSPs from either unpaired controls ($N = 23$) or US-alone controls ($N = 10$). We refer to this effect as activity-dependent amplification of facilitation. Walters & Byrne (1983) independently obtained similar results in another group of sensory neurones in *Aplysia*.

Fig. 3C compares the results of our cellular experiments with the results of behavioural experiments with the same protocol and parameters (testing was carried out 15 min after five training trials). Although the quantitative fit between these two sets of data is probably fortuitous, the fact that there is at least good qualitative agreement, combined with the fact that these synapses participate in mediating the behavioural response, strongly suggests that this activity-dependent amplification of facilitation is a mechanism of the behavioural conditioning. Lukowiak (1983) also observed parallelism between the cellular and behavioural results in similar experiments using a semi-intact preparation.

The activity-dependent facilitation shown in Fig. 3 could involve a variety of cellular mechanisms. For example, it could be due to Hebb-type synaptic plasticity, since the US in our experiments (tail shock) causes firing of the motor neurone. Hebb (1949) proposed that the strength of a synapse from neurone A to neurone B should increase if firing of A contributes to firing of B. This could occur at the synapse from the paired sensory neurone to the motor neurone, since the sensory neurone fires just before the US causes the motor neurone to fire. According to Hebb's postulate, spike activity in the postsynaptic (motor) neurone is critical. We tested this postulate in our system and found that spike activity in the postsynaptic neurone is neither necessary nor sufficient for the associative synaptic change to occur, because: (1) in one series of experiments the motor neurone was held at a hyperpolarized level and did not fire any action potentials in response to the US, and (2) intracellular stimulation of the motor neurone does not serve as an effective US (Carew, Hawkins, Abrams & Kandel, 1984). These results indicate that the activity-dependent facilitation shown in Fig. 3 is not due to Hebb-type synaptic plasticity.

If, on the other hand, our hypothesis is correct, activity-dependent facilitation should involve the same molecular machinery as normal presynaptic facilitation, but in an amplified form. We have tested this hypothesis in three ways. First, we investigated whether activity-dependent facilitation has a presynaptic mechanism, and whether it involves broadening of the action potentials in the sensory neurones as does normal presynaptic facilitation. To test this idea, we used a differential training procedure similar to the one shown in Fig. 3, but instead of measuring the amplitudes of the EPSPs in the motor neurone we measured the duration of the action potential in each sensory neurone before and after training (Hawkins *et al.* 1983a). We also bathed the abdominal ganglion (which contains the sensory neurones) in sea water containing tetraethylammonium, which blocks a non-serotonin sensitive K^+ current (the delayed rectifying current), making the duration of the action potential more sensitive to any changes in the remaining currents. In the example shown in Fig. 4 there was little change in the duration of the action potential in the unpaired neurone as a result of training, while there was substantial broadening of the action potential in the paired neurone. On

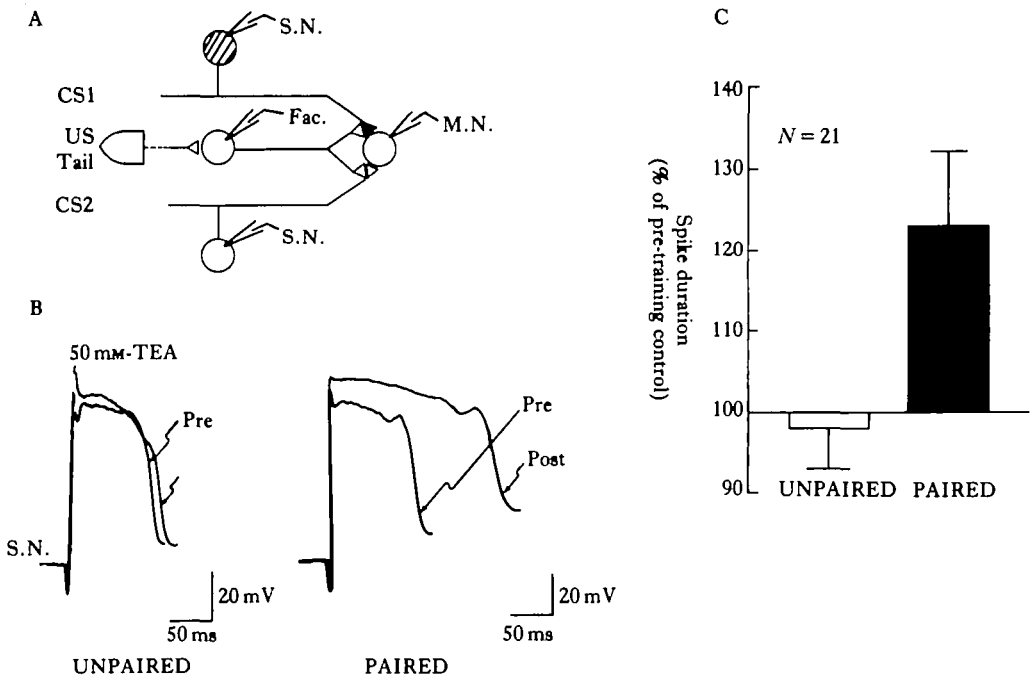

Fig. 4. Activity-dependent broadening of the action potential in a siphon sensory neurone in the presence of 50 mM-tetraethylammonium (TEA). (A) Experimental arrangement. (B) Examples of the action potentials in a paired and an unpaired sensory neurone before (Pre) and 3 h after training (Post). The Pre and Post action potentials for each neurone have been superimposed. Broadening of the action potential in the paired neurone was greater than that of the action potential in the unpaired neurone in the same experiment. (C) Average broadening of the action potentials in 21 experiments like the one shown in B. Testing was carried out 15 min after five training trials. Broadening of the action potentials in the paired sensory neurones was significantly greater than that in the unpaired sensory neurones ($P < 0.01$). (Adapted from Hawkins, Abrams, Carew & Kandel, 1983a.)

average, in 21 experiments broadening of the action potentials in the paired neurones was significantly greater than that in the unpaired neurones. This result supports the hypothesis that the mechanism of activity-dependent facilitation is an amplification of the same molecular mechanism underlying normal presynaptic facilitation.

As a second test, we investigated whether serotonin could substitute for tail shock as the US in these experiments, since it was already known that serotonin could substitute for tail shock in producing normal presynaptic facilitation (Brunelli *et al.* 1976; Klein & Kandel, 1978). We used the same experimental arrangement, except that we applied a brief puff of serotonin to the abdominal ganglion instead of shocking the tail (Abrams, Carew, Hawkins & Kandel, 1983). Again, broadening of the action potentials in sensory neurones which received serotonin paired with spike activity was significantly greater than that in sensory neurones which received unpaired training.

Broadening of action potentials could involve a change in more than one type of ionic current in the sensory neurones. As a third test, we examined whether our differential training procedure produces a change in the same ionic current (the serotonin-sensitive K^+ current, I_s) that is modulated during normal presynaptic

facilitation. The experimental arrangement was again the same, but instead of measuring the durations of the action potentials in the sensory neurones, we voltage-clamped them and measured the outward current produced by depolarizing voltage-clamp pulses in each neurone before and after training (R. D. Hawkins, unpublished data). As in the PSP experiments, we bathed the ganglion in normal sea water and used tail nerve shock as the US. In these experiments, there was a significantly greater decrease in the outward current in the paired neurones than the unpaired neurones. Since the parameters of the voltage-clamp pulse (20 mV for 500 ms) were chosen so that most of the outward current was carried by I_s , it is likely that this differential decrease in outward current represents a differential decrease in I_s . As a further test of this idea, we have begun to characterize the time and voltage dependence of the current which is modulated differentially in these experiments, and have found that they are similar to the time and voltage dependence of I_s .

The results of each of these three types of experiments support the hypothesis that

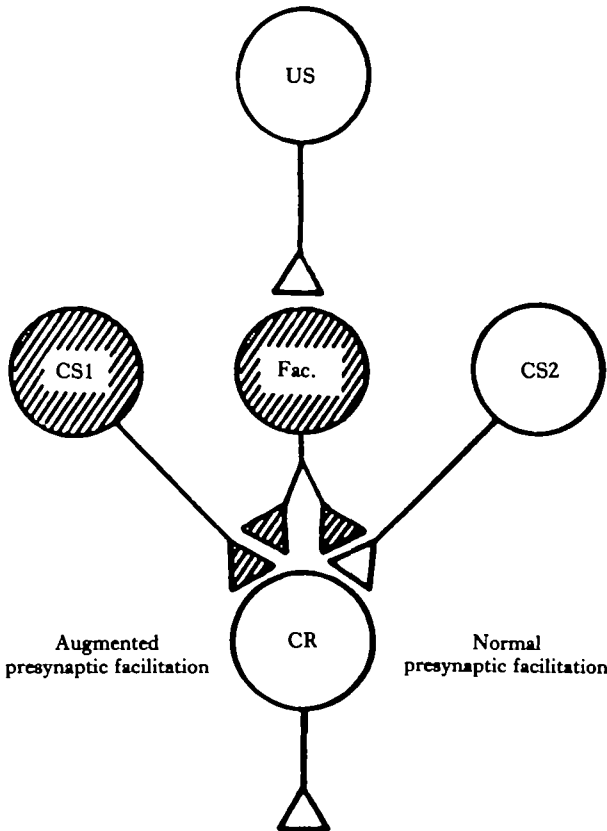

Fig. 5. Diagram of activity-dependent presynaptic facilitation, which is thought to underlie classical conditioning of the withdrawal reflex. The shading indicates neurones with temporally-paired spike activity. The US produces presynaptic facilitation of all of the sensory neurones (CS1 and CS2). That facilitation is augmented or amplified by the occurrence of spike activity in a sensory neurone just before the US is presented, as occurs in the paired pathway during behavioural conditioning. CR, motor neurone. (Adapted from Hawkins, Abrams, Carew & Kandel, 1983a.)

The cellular mechanism of activity-dependent facilitation, which we believe underlies conditioning of the withdrawal reflex, is an amplified form of the mechanism of normal presynaptic facilitation, which underlies sensitization of the reflex (Fig. 5). We do not yet know which aspect of the action potential in a sensory neurone interacts with the process of presynaptic facilitation to amplify it, or which step in the biochemical cascade leading to presynaptic facilitation is sensitive to the action potential. An attractive possibility is that the influx of Ca^{2+} with each action potential 'primes' the adenylyl cyclase in the sensory neurone, so that the cyclase produces more cAMP in response to the facilitating transmitter. Preliminary experiments have supported this hypothesis. First, pairing spike activity with serotonin produces greater broadening of the action potential in a sensory neurone in normal sea water than in low- Ca^{2+} sea water, which supports the idea that Ca^{2+} influx is the critical aspect of the spike activity (Abrams *et al.* 1983). Second, serotonin produces a greater increase in cAMP synthesis in sensory cells if it is paired with their spike activity than if it is not, which supports the idea that the cyclase or a preceding step in the cascade is modulated by the spike activity (Kandel *et al.* 1983; see Ocorr, Walters & Byrne, 1983 for a similar result in *Aplysia* tail sensory neurones). Further experiments are necessary to test these ideas more fully.

POSSIBLE GENERALITY OF THE MECHANISM

Activity-dependent amplification of facilitation can be thought of as a neuroselection theory of learning (as opposed to a neuroinstruction one). According to this viewpoint, learning alters the strengths of pre-existing synaptic connections in the brain, rather than creating totally new ones. Developmental processes, on the other hand, are thought to specify the existence, but not the exact strengths, of the connections. Support for the neuroselection viewpoint comes from experiments in which neural activity has been recorded in various regions of the brain during conditioning. The conditioned stimulus is generally found to produce a neural response in many areas of the brain, including motor areas, before conditioning begins. Conditioning increases (or decreases) the strengths of these neural responses, in some cases bringing them from below threshold to above threshold for producing a behavioural response (Woody & Brozek, 1969; Cegavske, Patterson & Thompson, 1979; Gold & Cohen, 1981).

One of the attractive features of activity-dependent facilitation as a mechanism of neuroselection is that it requires very little special circuitry. The basic requirements of this mechanism are: (1) a system of modulatory neurones which may project very diffusely (in principle, a single facilitator neurone which projected to all of the sensory neurones would be sufficient to account for the results reported here), and (2) differential spike activity in neurones which receive the modulatory input. Thus, during classical conditioning in *Aplysia*, the US produces a modulatory input and the CS produces spike activity in sensory neurones in the CS pathway. According to our hypothesis, the convergence of these two inputs determines which sensory neurone synapses will be selectively strengthened (Fig. 5). It seems likely that the abdominal sensory neurones are not unique, and that this mechanism may operate throughout the nervous system wherever these two requirements are satisfied. Indeed, Walters & Byrne (1983) have obtained similar results in another group of neurones in the pleural

ganglia of *Aplysia*, and Breen & Atwood (1983) have found that octopamine produces greater presynaptic facilitation if it is paired with spike activity in crayfish. More speculatively, it is attractive to think that this mechanism may also operate in the vertebrate nervous system, with the diffusely projecting aminergic or cholinergic systems playing the role that the facilitator neurones play in the abdominal ganglion of *Aplysia*. In support of this idea, stimulation of the locus coeruleus can serve as the US in a neural analogue of conditioning in lateral geniculate in pigeon (Gibbs, Broyles & Cohen, 1983), and iontophoresis of acetylcholine can serve as the US in producing an associative change in cortical neurones in cat (Woody, Swartz & Gruen, 1978). This hypothesis may reconcile neural connectionist ideas with the concept that memories are distributed in the vertebrate brain (e.g. Lashley, 1929). Thus it supposes that the neural events underlying the formation of any particular memory will be distributed wherever the CS and US inputs converge, and yet will consist of changes in the strengths of specific synapses in a strictly mechanistic fashion.

The neural mechanism of associative learning can be thought of as having two components: one that confers the requirement for temporal specificity, and thus selects the information to be stored, and another that is the physical store or engram itself. The mechanism of learning has been analysed on the cellular level in several invertebrate preparations, and the available data regarding the engram seem to form a fairly consistent pattern. Operant conditioning in locusts and classical conditioning in *Hermisenda* both appear to produce a persistent decrease in a K^+ current in identified neurones (Hoyle, 1979; Crow & Alkon, 1980; Alkon, Lederhendler & Shoukimas, 1982). In *Hermisenda*, there is evidence suggesting that this decrease may be caused by cAMP- or Ca^{2+} -calmodulin-dependent protein phosphorylation (Neary, Crow & Alkon, 1981; Alkon *et al.* 1983). There is also evidence indicating that both sensitization and avoidance conditioning in *Drosophila* may involve regulation of cAMP levels (Dudai *et al.* 1976; Byers, Davis & Kiger, 1981; Dudai, Uzzan & Zvi, 1983; Duerr & Quinn, 1982; Livingstone, Sziber & Quinn, 1982). More direct evidence indicates that sensitization of the gill and siphon withdrawal reflex in *Aplysia* is due to cAMP-dependent protein phosphorylation leading to a decrease in K^+ conductance (see above). The research reviewed in this paper suggests that the neuronal mechanism of classical conditioning in *Aplysia* is an amplification of the mechanism of sensitization and probably also involves a cAMP-mediated decrease in K^+ conductance. Thus, the available evidence supports the notion that each of these types of learning (operant conditioning, classical conditioning and sensitization) involves the same basic type of engram: a persistent decrease in a K^+ current. What differs in each case is where this decrease in K^+ current occurs and thus what its consequences are: in locust it appears to occur in motor neurones, increasing pacemaker activity; in *Hermisenda* it appears to occur in photoreceptors, enhancing generator potentials; and in *Aplysia* it appears to occur in sensory neurone terminals, facilitating transmitter release.

There is less agreement regarding the pairing or association component of the mechanism in these preparations. In *Aplysia*, the association mechanism is thought to be activity dependence of the decrease in K^+ current in the sensory neurone terminals, leading to an associative increase in transmitter release. If the same mechanism occurred in the cell body or integrative region of a neurone it could lead

■ associative increases in neuronal excitability or spontaneous firing rate. Thus, for example, if the decreases in K^+ current observed in other preparations were triggered by (hypothetical) modulatory synaptic inputs produced by the reinforcing stimuli, they might exhibit activity dependence similar to that seen in *Aplysia*. In classical conditioning in *Hermisenda*, the effect of the modulatory input would be amplified if it were temporally paired with a generator potential in the photoreceptor, leading to an associative increase in excitability of the photoreceptor. Interestingly, McElearney & Farley (1983) have found that an optic ganglion homogenate and serotonin both produce a decrease in membrane conductance in the photoreceptor, suggesting that serotonin could be the hypothetical modulatory transmitter. In positive operant conditioning in locust, the effect of the modulatory input would be amplified if it were temporally paired with spontaneous spike activity in the motor neurone, leading to an associative increase in pacemaker activity.

Although these ideas are speculative, they offer the possibility of accounting for the cellular information on associative learning in invertebrates with a single mechanism: activity-dependent modulation of a cAMP-mediated decrease in K^+ current. There is some evidence for a similar mechanism in vertebrates. Woody *et al.* (1978) found that iontophoresis of acetylcholine or injection of cyclic GMP produce longer lasting increases in membrane resistance in neurones of coronal-precruciate cortex if they are paired with intracellularly produced spike activity in those neurones than if they are not. This effect is implicated in eye blink conditioning, because Brons & Woody (1980) recorded a prolonged increase in excitability of neurones in coronal-precruciate cortex of cats that had received such conditioning.

CONTINGENCY IN CONDITIONING OF THE WITHDRAWAL REFLEX

The experiments reviewed thus far were all concerned with the effect of temporal pairing or contiguity in conditioning. Studies of conditioning in vertebrates have shown that animals learn not only about the contiguity of events but also about their correlation or contingency (i.e. how well one event predicts another). Thus, for example, Rescorla (1968) has shown that presentation of extra, unpaired or unpredicted USs during training (which decreases the degree to which the US is contingent on the CS) decreases conditioning. Sahley, Rudy & Gelperin (1981) have shown that a similar effect occurs in conditioning in the garden slug, *Limax maximus*. We therefore investigated whether this effect also occurs in conditioning of the *Aplysia* siphon withdrawal reflex (Hawkins *et al.* 1983*b*). Animals were divided into two groups, one of which received normal differential conditioning, exactly as described above. The second group received the same training, but in addition received extra, unpredicted USs interspersed during training. Thus, both groups experienced the same degree of contiguity (the same number of pairings of the CS^+ and the US), but for the second group the US was less contingent on the CS^+ (i.e. the CS^+ was a poorer predictor that the US was about to occur). The animals receiving the unpredicted USs showed significantly less conditioning than the animals receiving normal training, both in terms of the difference in response to the CS^+ and the CS^- and in the absolute level of response to the CS^+ following training. Several controls suggested that this difference in learning was not due to the difference in US frequency or

number for the two groups, but rather was due to the difference in the degree to which the US was contingent on the CS⁺.

This result again shows a similarity at the behavioural level between conditioning in *Aplysia* and in vertebrates. Nonetheless, we found it somewhat surprising, since a naive prediction from the mechanism we have proposed for classical conditioning of the withdrawal reflex (activity-dependent amplification of presynaptic facilitation) would be that extra USs should simply produce extra sensitization, and this is not what happened. Hawkins & Kandel (1984) have proposed a simple cellular hypothesis that might account for these results, which is that repeated presentation of the US may lead to habituation of its effectiveness due to synaptic depression in the US pathway. Presentation of extra, unpaired USs would then be expected to produce more habituation, resulting in a decrease in effectiveness of the US on the paired trials and thus a decrease in learning. A quantitative simulation based on this idea has produced results very similar to the results of the behavioural experiments. However, this hypothesis is probably somewhat simplistic, and I doubt that it can provide a complete explanation for the effect of contingency. I mention it primarily to illustrate a more general idea, which is that the neural mechanisms of higher-order features of learning, such as the effect of contingency, may be built by putting together combinations of the mechanisms of simpler forms of learning, such as synaptic depression and facilitation. At the moment this proposal is pure speculation, but I hope that it will provide a useful framework for further investigation into the neuronal mechanisms of learning.

Preparation of this article was supported in part by grants from the National Institute of General Medical Sciences (GM-32099) and the System Development Foundation (276). I am grateful to Tom Abrams, Greg Clark and Eric Kandel for their comments on an earlier draft of this paper, Kathrin Hilten and Louise Katz for preparing the figures, and Harriet Ayers for preparation of the manuscript.

REFERENCES

- ABRAMS, T. W., CAREW, T. J., HAWKINS, R. D. & KANDEL, E. R. (1983). Aspects of the cellular mechanism of temporal specificity in conditioning in *Aplysia*: preliminary evidence for Ca²⁺ influx as a signal of activity. *Soc. Neurosci. Abstr.* **9**, 168.
- ALKON, D. L., ACOSTA-URQUIDI, J., OLDS, J., KUZMA, G. & NEARY, J. T. (1983). Protein kinase injection reduces voltage-dependent potassium currents. *Science, N.Y.* **219**, 303–306.
- ALKON, D. L., LEDERHENDLER, I. & SHOUKIMAS, J. J. (1982). Primary changes of membrane currents during retention of associative learning. *Science, N.Y.* **215**, 693–695.
- BAILEY, C. H. & CHEN, M. (1983). Morphological basis of long-term habituation and sensitization in *Aplysia*. *Science, N.Y.* **220**, 91–93.
- BAILEY, C. H., HAWKINS, R. D. & CHEN, M. (1983). Uptake of (³H) serotonin in the abdominal ganglion of *Aplysia californica*: further studies on the morphological and biochemical basis of presynaptic facilitation. *Brain Res.* **272**, 71–81.
- BAILEY, C. H., HAWKINS, R. D., CHEN, M. C. & KANDEL, E. R. (1981). Interneurons involved in mediation and modulation of gill-withdrawal reflex in *Aplysia*. IV. Morphological basis of presynaptic facilitation. *J. Neurophysiol.* **45**, 340–360.
- BERNIER, L., CASTELLUCCI, V. F., KANDEL, E. R. & SCHWARTZ, J. H. (1982). Facilitatory transmitter causes a selective and prolonged increase in adenosine 3': 5'-monophosphate in sensory neurons mediating the gill and siphon withdrawal reflex in *Aplysia*. *J. Neurosci.* **2**, 1682–1691.
- BREEN, C. A. & ATWOOD, H. L. (1983). Octopamine – a neurohormone with presynaptic activity-dependent effects at crayfish neuromuscular junctions. *Nature, Lond.* **303**, 716–718.
- BRONS, J. F. & WOODY, C. D. (1980). Long-term changes in excitability of cortical neurons after Pavlovian conditioning and extinction. *J. Neurophysiol.* **44**, 605–615.

- BRUNELLI, M., CASTELLUCCI, V. & KANDEL, E. R. (1976). Synaptic facilitation and behavioral sensitization in *Aplysia*: possible role of serotonin and cAMP. *Science, N.Y.* **194**, 1178–1181.
- BYERS, D., DAVIS, R. L. & KIGER, J. A. (1981). Defect in cyclic AMP phosphodiesterase due to the dunce mutation of learning in *Drosophila melanogaster*. *Nature, Lond.* **289**, 79–81.
- CAJAL, S. R. (1911). *Histologie du Systeme Nerveux de L'Homme et des Vertebres*, Vol. II, (translated by L. Azoulay). Paris: Maloine. Republished 1955, Madrid: Instituto Ramon y Cajal.
- CAREW, T. J., HAWKINS, R. D., ABRAMS, T. W. & KANDEL, E. R. (1984). A test of Hebb's postulate at identified synapses which mediate classical conditioning in *Aplysia*. *J. Neurosci.* **4**, 1217–1224.
- CAREW, T. J., HAWKINS, R. D. & KANDEL, E. R. (1983). Differential classical conditioning of a defensive withdrawal reflex in *Aplysia californica*. *Science, N.Y.* **219**, 397–400.
- CAREW, T. J., WALTERS, E. T. & KANDEL, E. R. (1981). Classical conditioning in a simple withdrawal reflex in *Aplysia californica*. *J. Neurosci.* **1**, 1426–1437.
- CASTELLUCCI, V. & KANDEL, E. R. (1976). Presynaptic facilitation as a mechanism for behavioral sensitization in *Aplysia*. *Science, N.Y.* **194**, 1176–1178.
- CASTELLUCCI, V. F., KANDEL, E. R., SCHWARTZ, J. H., WILSON, F. D., NAIRN, A. C. & GREENGARD, P. (1980). Intracellular injection of the catalytic subunit of cyclic AMP-dependent protein kinase simulates facilitation of transmitter release underlying behavioral sensitization in *Aplysia*. *Proc. natn. Acad. Sci. U.S.A.* **77**, 7492–7496.
- CASTELLUCCI, V. F., NAIRN, A., GREENGARD, P., SCHWARTZ, J. H. & KANDEL, E. R. (1982). Inhibitor of adenosine 3':5'-monophosphate-dependent protein kinase blocks presynaptic facilitation in *Aplysia*. *J. Neurosci.* **2**, 1673–1681.
- CASTELLUCCI, V., PINSKER, H., KUPFERMANN, I. & KANDEL, E. R. (1970). Neuronal mechanisms of habituation and dishabituation of the gill-withdrawal reflex in *Aplysia*. *Science, N.Y.* **167**, 1745–1748.
- CEGAVSKE, C. F., PATTERSON, M. M. & THOMPSON, R. F. (1979). Neuronal unit activity in the abducens nucleus during classical conditioning of the nictitating membrane response in the rabbit (*Oryctolagus cuniculus*). *J. comp. physiol. Psychol.* **93**, 595–609.
- COHEN, D. H. (1969). Development of a vertebrate experimental model for cellular neurophysiological studies of learning. *Conditional Reflex* **4**, 61–80.
- CROW, T. J. & ALKON, D. L. (1978). Retention of an associative behavioral change in *Hermisenda*. *Science, N.Y.* **201**, 1239–1241.
- CROW, T. J. & ALKON, D. L. (1980). Associative behavioral modification in *Hermisenda*: cellular correlates. *Science, N.Y.* **209**, 412–414.
- DUDAI, Y., JAN, Y.-N., BYERS, D., QUINN, W. G. & BENZER, S. (1976). Dunce, a mutant of *Drosophila* deficient in learning. *Proc. natn. Acad. Sci. U.S.A.* **73**, 1684–1688.
- DUDAI, Y., UZZAN, A. & ZVI, S. (1983). Abnormal activity of adenylate cyclase in the *Drosophila* memory mutant rutabaga. *Neurosci. Letts* **42**, 207–212.
- DUERR, J. S. & QUINN, W. G. (1982). Three *Drosophila* mutants that block associative learning also affect habituation and sensitization. *Proc. natn. Acad. Sci. U.S.A.* **79**, 3646–3650.
- FRAZIER, W. T., KANDEL, E. R., KUPFERMANN, I., WAZIRI, R. & COGGESHALL, R. E. (1967). Morphological and functional properties of identified neurons in the abdominal ganglion of *Aplysia californica*. *J. Neurophysiol.* **30**, 1288–1351.
- GELPERIN, A. (1975). Rapid food-aversion learning by a terrestrial mollusk. *Science, N.Y.* **189**, 567–570.
- GIBBS, C. M., BROYLES, J. L. & COHEN, D. H. (1983). Further studies of the involvement of locus coeruleus in plasticity of avian lateral geniculate neurons during learning. *Soc. Neurosci. Abstr.* **9**, 641.
- GOLD, M. R. & COHEN, D. H. (1981). Modification of the discharge of vagal cardiac neurons during learned heart rate change. *Science, N.Y.* **214**, 345–347.
- GORMEZANO, I. (1972). Investigations of defense and reward conditioning in the rabbit. In *Classical Conditioning II: Current Research and Theory*, (eds A. H. Black & W. F. Prokasy). New York: Appleton-Century-Crofts.
- HAWKINS, R. D. (1981a). Identified facilitating neurons are excited by cutaneous stimuli used in sensitization and classical conditioning of *Aplysia*. *Soc. Neurosci. Abstr.* **7**, 354.
- HAWKINS, R. D. (1981b). Interneurons involved in mediation and modulation of gill-withdrawal reflex in *Aplysia*. III. Identified facilitating neurons increase Ca^{2+} current in sensory neurons. *J. Neurophysiol.* **45**, 327–339.
- HAWKINS, R. D., ABRAMS, T. W., CAREW, T. J. & KANDEL, E. R. (1983a). A cellular mechanism of classical conditioning in *Aplysia*: activity-dependent amplification of presynaptic facilitation. *Science, N.Y.* **219**, 400–405.
- HAWKINS, R. D., CAREW, T. J. & KANDEL, E. R. (1983b). Effects of interstimulus interval and contingency on classical conditioning in *Aplysia*. *Soc. Neurosci. Abstr.* **9**, 168.
- HAWKINS, R. D., CASTELLUCCI, V. F. & KANDEL, E. R. (1981). Interneurons involved in mediation and modulation of gill-withdrawal reflex in *Aplysia*. II. Identified neurons produce heterosynaptic facilitation contributing to behavioral sensitization. *J. Neurophysiol.* **45**, 315–326.
- HAWKINS, R. D. & KANDEL, E. R. (1984). Is there a cell biological alphabet for simple forms of learning? *Psychol. Rev.* **91**, 375–391.
- HEBB, D. O. (1949). *Organization of Behavior*. New York: John Wiley & Sons.
- HORRIDGE, G. A. (1962). Learning of leg position by headless insects. *Nature, Lond.* **193**, 697–698.

- HOYLE, G. (1979). Instrumental conditioning of the leg lift in the locust. *Neurosci. Res. Progr. Bull.* **17**, 577-586.
- KAMIN, L. J. (1969). Predictability, surprise, attention and conditioning. In *Punishment and Aversive Behavior*, (eds B. A. Campbell & R. M. Church). New York: Appleton-Century-Crofts.
- KANDEL, E. R., ABRAMS, T., BERNIER, L., CAREW, T. J., HAWKINS, R. D. & SCHWARTZ, J. A. (1983). Classical conditioning and sensitization share aspects of the same molecular cascade in *Aplysia*. *Cold Spring Harb. Symp. quant. Biol.* **48**, 821-830.
- KANDEL, E. R. & SCHWARTZ, J. H. (1982). Molecular biology of learning: modulation of transmitter release. *Science, N.Y.* **218**, 433-443.
- KISTLER, H. B., JR., HAWKINS, R. D., KOESTER, J., KANDEL, E. R. & SCHWARTZ, J. H. (1983). Immunocytochemical studies of neurons producing presynaptic facilitation in the abdominal ganglion of *Aplysia californica*. *Soc. Neurosci. Abstr.* **9**, 915.
- KLEIN, M., CAMARDO, J. & KANDEL, E. R. (1982). Serotonin modulates a specific potassium current in the sensory neurons that show presynaptic facilitation in *Aplysia*. *Proc. natn. Acad. Sci. U.S.A.* **79**, 5713-5717.
- KLEIN, M. & KANDEL, E. R. (1978). Presynaptic modulation of voltage-dependent Ca^{2+} current: mechanism for behavioral sensitization. *Proc. natn. Acad. Sci. U.S.A.* **75**, 3512-3516.
- KLEIN, M. & KANDEL, E. R. (1980). Mechanism of calcium current modulation underlying presynaptic facilitation and behavioral sensitization in *Aplysia*. *Proc. natn. Acad. Sci. U.S.A.* **77**, 6912-6916.
- KRASNE, F. B. (1969). Excitation and habituation of the crayfish escape reflex: the depolarization response in lateral giant fibres of the isolated abdomen. *J. exp. Biol.* **50**, 29-46.
- KUPFFERMANN, I., CASTELLUCCI, V., PINSKER, H. & KANDEL, E. R. (1970). Neuronal correlates of habituation and dishabituation of the gill-withdrawal reflex in *Aplysia*. *Science, N.Y.* **167**, 1743-1745.
- LASHLEY, K. S. (1929). *Brain Mechanisms and Intelligence: A Quantitative Study of Injuries to the Brain*. Chicago: Chicago University Press.
- LIVINGSTONE, M. S., SZIBER, P. & QUINN, W. G. (1982). Defective adenylate cyclase in the *Drosophila* learning mutant, rutabaga. *Soc. Neurosci. Abstr.* **8**, 384.
- LUKOWIAK, K. (1983). Associative learning in an *in vitro* *Aplysia* preparation: facilitation at a sensory motor neuron synapse. *Soc. Neurosci. Abstr.* **9**, 169.
- LUKOWIAK, K. & SAHLEY, C. (1981). The *in vitro* classical conditioning of the gill withdrawal reflex of *Aplysia californica*. *Science, N.Y.* **212**, 1516-1518.
- MCELEARNEY, A. & FARLEY, J. (1983). Persistent changes in *Hermisenda* B photoreceptor membrane properties with associative training: a role for pharmacological modulation. *Soc. Neurosci. Abstr.* **9**, 915.
- MPITSOS, G. J. & COLLINS, S. D. (1975). Learning: rapid aversive conditioning in the gastropod mollusk *Pleurobranchaea*. *Science, N.Y.* **188**, 954-957.
- NEARY, J. T., CROW, T. & ALKON, D. L. (1981). Change in a specific phosphoprotein following associative learning in *Hermisenda*. *Nature, Lond.* **293**, 658-660.
- OCORR, K. A., WALTERS, E. T. & BYRNE, J. H. (1983). Associative conditioning analog in *Aplysia* tail sensory neurons selectively increases cAMP content. *Soc. Neurosci. Abstr.* **9**, 169.
- PINSKER, H. M., HENING, W. A., CAREW, T. J. & KANDEL, E. R. (1973). Long-term sensitization of a defensive withdrawal reflex in *Aplysia*. *Science, N.Y.* **182**, 1039-1042.
- PINSKER, H., KUPFFERMANN, I., CASTELLUCCI, V. & KANDEL, E. R. (1970). Habituation and dishabituation of the gill-withdrawal reflex in *Aplysia*. *Science, N.Y.* **167**, 1740-1742.
- QUINN, W. G., HARRIS, W. A. & BENZER, S. (1974). Conditioned behavior in *Drosophila melanogaster*. *Proc. natn. Acad. Sci. U.S.A.* **71**, 708-712.
- RESCORLA, R. A. (1967). Pavlovian conditioning and its proper control procedures. *Psychol. Rev.* **74**, 71-80.
- RESCORLA, R. A. (1968). Probability of shock in the presence and absence of CS in fear conditioning. *J. comp. physiol. Psychol.* **66**, 1-5.
- SAHLEY, C., RUDY, J. W. & GELPERIN, A. (1981). An analysis of associative learning in a terrestrial mollusc. I. Higher-order conditioning, blocking, and a transient US pre-exposure effect. *J. comp. Physiol.* **144**, 1-8.
- SEGELBAUM, S. A., CAMARDO, J. S. & KANDEL, E. R. (1982). Serotonin and cyclic AMP close single K^+ channels in *Aplysia* sensory neurones. *Nature, Lond.* **299**, 413-417.
- SPENCER, W. A., THOMPSON, R. F. & NIELSON, D. R., JR. (1966). Response decrement of the flexion reflex in the acute spinal cat and transient restoration by strong stimuli. *J. Neurophysiol.* **29**, 221-239.
- THOMPSON, R. F., BERGER, T. W., CEGAVSKE, C. F., PATTERSON, M. M., ROEMER, R. A., TEYLER, T. J. & YOUNG, R. A. (1976). The search for the engram. *Am. Psychol.* **31**, 209-227.
- WALTERS, E. T. & BYRNE, J. H. (1983). Associative conditioning of single sensory neurons suggests a cellular mechanism for learning. *Science, N.Y.* **219**, 405-408.
- WALTERS, E. T., CAREW, T. J. & KANDEL, E. R. (1979). Classical conditioning in *Aplysia californica*. *Proc. natn. Acad. Sci. U.S.A.* **76**, 6675-6679.
- WOODY, C. D. & BROZEK, G. (1969). Changes in evoked responses from facial nucleus of cat with conditioning and extinction of an eye blink. *J. Neurophysiol.* **32**, 717-726.
- WOODY, C. D., SWARTZ, B. E. & GRUEN, E. (1978). Effects of acetylcholine and cyclic GMP on input resistance of cortical neurons in awake cats. *Brain Res.* **158**, 373-395.
- ZUCKER, R. S. (1972). Crayfish escape behavior and central synapses. II. Physiological mechanisms underlying behavioral habituation. *J. Neurophysiol.* **35**, 621-637.