

## ANIMAL PLASMA MEMBRANE ENERGIZATION BY CHEMIOSMOTIC H<sup>+</sup> V-ATPases

WILLIAM R. HARVEY<sup>1,\*</sup> AND HELMUT WIECZOREK<sup>2</sup>

<sup>1</sup>Department of Biology, Temple University, Philadelphia, PA 19122, USA and <sup>2</sup>Institute of Zoology, Munich University, D-80333 Munich, Germany

### Summary

Proton-motive forces are thought to be less important than sodium-motive forces in energizing animal membranes. On the supply side, proton-motive forces across mitochondrial inner membranes are well-known energizers of ATP synthesis, catalyzed by F-type ATP synthases. However, on the demand side, proton-motive forces, generated from ATP by V-ATPases, are not widely accepted as energizers of animal membranes; instead, sodium-motive forces, generated by P-ATPases, are thought to predominate. During the 1980s, Anraku, Nelson, Forgac and others showed that proton-motive forces from H<sup>+</sup> V-ATPases energize endomembranes of all eukaryotic cells; in most cases, chloride ions accompany the protons and the output compartment is acidified. Unexpectedly, numerous examples of animal *plasma membrane* energization by proton-motive forces are now appearing. In many insect epithelia, H<sup>+</sup> V-ATPases generate transmembrane voltages which secondarily drive sensory signalling, fluid secretion and even alkalization, rather than acidification. Plasma membranes of phagocytes and osteoclasts as well as polarized membranes of epithelia in vertebrate kidney, bladder and epididymis, even apical membranes of frog skin epithelial cells, are now known to be energized by proton-motive forces. The list of proton-energized animal plasma membranes grows daily and includes cancer cells.

The localization of H<sup>+</sup> V-ATPases either on endomembranes or on plasma membranes may reflect a key event in their evolution. Proton-motive ATPases, like the H<sup>+</sup> A-ATPases in present-day archaeobacteria, appear to be ancestors of both H<sup>+</sup> F-ATP synthases and H<sup>+</sup> V-ATPases. On the basis of a greater than 25% overall sequence identity and much higher identity in the nucleotide-binding and regulatory sites, Nelson and others have argued that the A and B subunits of V-ATPases, like the corresponding  $\beta$  and  $\alpha$  subunits of F-ATP synthases,

derive from common 'A-ATPase-like' ancestral subunits. They postulate that oxygen, introduced into the earth's atmosphere by cyanobacteria, was a selective agent as these key subunits diverged during evolution. Forgac has focused the issue more sharply by showing that the catalytic 'A' subunit of H<sup>+</sup> V-ATPases has two key sulfhydryl residues that are proximal to each other in the tertiary structure; these residues form a disulfide bond under oxidizing conditions, thereby inactivating the enzyme. The corresponding  $\beta$  subunit of H<sup>+</sup> F-ATPases lacks such sulfhydryl residues. Perhaps because their plasma membranes are the site of oxygen-dependent ATP synthesis, which would select against their sulfhydryl-containing regulatory sites, eubacterial cells lack H<sup>+</sup> V-ATPases. This retention of the regulatory cysteine residue in the active sites during evolution may explain why H<sup>+</sup> V-ATPases are commonly found in the reducing atmosphere of the cytoplasm, where they would be active, rather than in the putatively oxidizing atmosphere of many plasma membranes, where they would be inactive. It may also explain why animal plasma membrane H<sup>+</sup> V-ATPases are commonly found in 'mitochondria-rich' cells. We suggest that the high oxygen affinity of cytochrome oxidase leads to localized reducing conditions near mitochondria which would allow H<sup>+</sup> V-ATPases to remain active in plasma membranes of such cells. Moreover, this 'redox modulation mechanism' may obviate the need to evoke two types of enzyme to explain selective targeting of H<sup>+</sup> V-ATPases to plasma membranes or endomembranes: membrane that contains a single form of H<sup>+</sup> V-ATPase may cycle between the membranes of the cytoplasmic organelles and the cell surface, the enzyme being active only when reducing conditions remove the disulfide bonding restraint.

Key words: proton-motive force, proton-translocating vacuolar-type ATPase, mitochondria-rich cells, redox modulation.

### Proton versus sodium ion paradigms

Our primary purpose in this review is to argue that plasma membranes in many animal epithelial cells are energized by proton-motive forces generated by H<sup>+</sup> V-ATPases. After proton-motive forces have been defined, the isolation and

identification of H<sup>+</sup> V-ATPases in *Manduca sexta* goblet cell apical membranes will be discussed in relation to the cloning and sequencing of most of the subunits. Noting evidence that the so-called K<sup>+</sup> pump is composed of an H<sup>+</sup> V-ATPase,

\*Address for correspondence: Whitney Laboratory, University of Florida, St Augustine, FL 32086, USA (e-mail: lem@icbr.ifas.ufl.edu).

$K^+/2H^+$  antiporter in the goblet cell apical membrane (GCAM), we will refute a claim that the V-ATPase transports  $K^+$  rather than  $H^+$ . Many animal plasma membranes that are energized by proton-motive forces will be described. The divergent evolution of V-ATPases from F-ATP synthases will be discussed in relation to Michael Forgac's hypothesis that reducing conditions favor  $H^+$  V-ATPase activation. The suspicion that either active or inactive  $H^+$  V-ATPases are present in apical plasma membranes of nearly all animal epithelial cells will be voiced. A hypothesis that mitochondria act as 'reducing agents' will be used to explain why active  $H^+$  V-ATPases are found so frequently in so-called 'mitochondria-rich' cells. Finally, voltage-driven  $K^+/2H^+$  antiport and amino acid: $K^+$  symport will be discussed.

#### Chemiosmotic and covalent coupling in ATP synthesis

The constancy of intracellular constituents, like that of extracellular fluids (Bernard, 1878/1879), implies a balance between energy-trapping and energy-utilizing mechanisms. The concentration of ATP, the key constituent, is held constant within cells by a balance between ATP synthesis and ATP utilization. Two ways to make ATP have evolved in nature – chemiosmotic coupling of ATP synthesis to proton electrochemical gradients and covalent coupling of ATP synthesis to chemical reactions *via* phosphorylated intermediates. Chemiosmotically coupled ATP synthesis is catalyzed by  $H^+$  F-ATP synthases, such as those in the oxidative phosphorylation pathway of mitochondria (see Fillingame, 1997). Covalently coupled ATP synthesis is catalyzed by phosphoenzymes, such as those in the glycolytic pathway. Two ions have evolved as primary membrane energizers – protons and sodium ions. ATP hydrolysis ( $\Delta G_{ATP/m}$ ) *via*  $H^+$  F-ATPase,  $H^+$  V-ATPase and  $H^+$  P-ATPase yields a proton electrochemical gradient ( $RT \ln [H^+]_i / [H^+]_o + zF\Delta\Psi \equiv \Delta\bar{\mu}_{H^+}$ ). Expressed in volts,  $\Delta\bar{\mu}_{H^+}/F$  is called the proton-motive force,  $\Delta p$  (Mitchell, 1961). At 25 °C.  $\Delta p \approx 60 \text{ mV} (\Delta pH) + \Delta\Psi$ . Similarly, ATP hydrolysis *via* the  $Na^+/K^+$  P-ATPase yields a  $Na^+$  electrochemical gradient (see

below for definitions of variables and Appendix for further discussion of transport nomenclature).



#### Advantages of protons

Just as continuous chains of electrons carry current rapidly through metals, continuous chains of protons, hydrogen-bonded to water, carry current rapidly through aqueous solutions. Because ion-translocating channels are water-lined, this continuity results in protons having nearly an order of magnitude higher mobility than any other ion in channels (Hille, 1992). It is therefore not surprising that protons are widespread carriers of electrical current through biological membranes. The concentration of protons is seldom greater than  $10^{-4} \text{ mol l}^{-1}$  in cells, so proton currents do not contribute significantly to membrane conductances or cellular osmotic balance. Proton electrochemical gradients are generated by P-ATPases that operate with a phosphorylated intermediate, e.g. the  $H^+$  P-ATPase of yeast, fungal and plant plasma membranes and the  $K^+/H^+$  P-ATPase of gastric mucosa. Proton electrochemical gradients are also generated chemiosmotically, i.e. without any chemical intermediate (Mitchell, 1961) by  $H^+$  V-ATPases. In rare cases,  $Na^+$  gradients are generated chemiosmotically by  $Na^+$  V-ATPases (e.g. Kakinuma and Igarashi, 1989, 1994).

#### Alleged absence of $\Delta\bar{\mu}_{H^+}/F$ , ATP interconversion in animal plasma membranes

Proton electrochemical gradients and ATP are interconvertible currencies – proton electrochemical gradients drive ATP synthesis and ATP hydrolysis drives the formation of proton electrochemical gradients (Harold, 1986). This remarkable interconversion between ATP and proton electrochemical gradients is found throughout nature. In bacteria, proton electrochemical gradients, which are generated across the plasma membrane by electron-transport-dependent proton pumps, drive the  $H^+$  F-ATP synthase as well as various antiporters and symporters (Fig. 1). In yeast and fungi, an  $H^+$  P-ATPase generates a proton

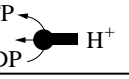
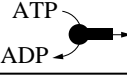
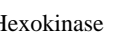
Energization of bacterial membranes  
(selected examples from a vast collection)

Energy coupling	ATP synthesis	ATP hydrolysis
Chemiosmotic $\Delta G/F = \Delta\bar{\mu}_{H^+}/F = \Delta\Psi - 59\Delta pH$	$H^+$ F-ATP synthase (plasma membrane) 	$H^+$ F-ATPase 
Phosphorylated intermediate Glucose 6-P	Glycolytic enzymes (cytoplasm) Hexokinase 	Kdp P-ATPase 

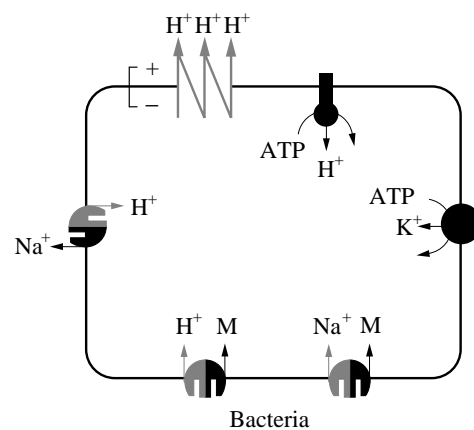

Fig. 1. In bacteria, the electron transport chain generates proton electrochemical gradients that drive both primary and secondary transporters that are located in plasma membranes. M, metabolite; Kdp,  $K^+$  dependent.

Energization of yeast and fungal membranes  
(selected examples)

Energy coupling	ATP synthesis	ATP hydrolysis	
		Endomembrane	Plasma membrane
Chemiosmotic $\Delta\bar{\mu}_{H^+}/F = \Delta\psi - 59\Delta pH$	H <sup>+</sup> F-ATP synthase (mitochondria)	H <sup>+</sup> V-ATPase	Not common
Phosphorylated intermediate	Glycolytic enzymes (cytoplasm)	Not common	H <sup>+</sup> P-ATPase

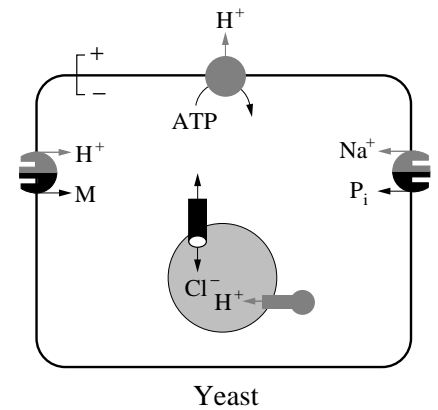

Fig. 2. In yeast and fungi, primary H<sup>+</sup> P-ATPases generate proton electrochemical gradients across plasma membranes and primary H<sup>+</sup> V-ATPases generate such gradients across vacuolar membranes. Secondary transporters and channels use the gradients for transport work. M, metabolite; P<sub>i</sub>, inorganic phosphate.

Energization of plant membranes  
(selected examples; modified from Sze *et al.* 1992)

Energy coupling	ATP synthesis	ATP hydrolysis	
		Endomembrane	Plasma membrane
Chemiosmotic $\Delta\bar{\mu}_{H^+}/F = \Delta\psi - 59\Delta pH$	H <sup>+</sup> F-ATP synthase (chloroplast)	H <sup>+</sup> V-ATPase	Not common
Phosphorylated intermediate	Glycolytic enzymes (cytoplasm)	Not common	H <sup>+</sup> P-ATPase

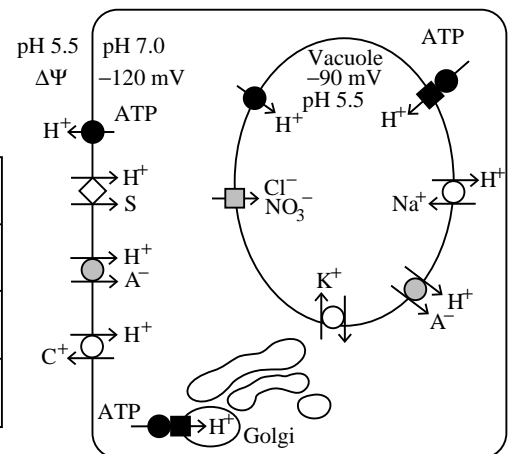

Fig. 3. Plants resemble yeast and fungi in that primary H<sup>+</sup> P-ATPases generate proton electrochemical gradients across plasma membranes and primary H<sup>+</sup> V-ATPases generate such gradients across the tonoplast. Secondary transporters and channels use the gradients for transport work. A<sup>-</sup>, anion; C<sup>+</sup>, cation; S, substrate. Simplified from Sze *et al.* (1992).

electrochemical gradient across the plasma membrane, whereas an H<sup>+</sup> V-ATPase energizes the vacuolar membrane (Anraku *et al.* 1989; Fig. 2). The situation is similar in plants, where the proton-motive force across the plasma membrane is generated by an H<sup>+</sup> P-ATPase and the tonoplast membrane is energized by an H<sup>+</sup> V-ATPase (Fig. 3). Finally, animal endomembranes are energized by an H<sup>+</sup> V-ATPase. It is only in animal plasma membranes that proton currents are thought to be unimportant – few people believe that ATP hydrolysis sets up proton electrochemical gradients across animal plasma membranes and that these gradients drive secondary symporters and antiporters, just as they do in all the rest of the living world (Fig. 4), even though proton-linked antiporters, e.g. the Na<sup>+</sup>/H<sup>+</sup> exchanger, are common in animal plasma membranes.

*The sodium ion paradigm*

Na<sup>+</sup>, not H<sup>+</sup>, is widely believed to energize animal plasma membranes. The fragile animal plasma membrane is

osmotically vulnerable; water would be expected to enter the hypertonic cytoplasm, causing the cells to swell and burst. However, the Na<sup>+</sup>/K<sup>+</sup> P-ATPase pumps Na<sup>+</sup> out of cells, incidently maintaining a Na<sup>+</sup> chemical gradient with [Na<sup>+</sup>] high outside and low inside. Simultaneously, the Na<sup>+</sup>/K<sup>+</sup> P-ATPase pumps K<sup>+</sup> into cells. Cell membranes have K<sup>+</sup> channels through which K<sup>+</sup> diffuses out faster than any other ion and, almost instantaneously, an inside-negative voltage balances the K<sup>+</sup> gradient. The cell membrane is relatively impermeable to Na<sup>+</sup>, so both this voltage and the Na<sup>+</sup> chemical gradient remain poised to drive Na<sup>+</sup> back into cells, thereby doing transport work (Dean, 1941). For example, glucose is driven into cells *via* the glucose:Na<sup>+</sup> symporter (cotransporter) and Ca<sup>2+</sup> is driven out of cells *via* the Ca<sup>2+</sup>/Na<sup>+</sup> antiporter (exchanger) (Hediger, 1994).

Numerous alternatives notwithstanding, the global bioenergetic scheme is simple and elegant. In chemiosmotic systems of bacteria, yeast and plants, proton electrochemical gradients drive ATP synthesis and ATP hydrolysis forms proton

## Energization of animal membranes

Energy coupling	ATP synthesis	ATP hydrolysis	
		Endomembrane	Plasma membrane
Chemiosmotic $\Delta\bar{\mu}_{H^+}/F = \Delta\psi - 59\Delta pH$	H <sup>+</sup> F-ATP synthase (mitochondria)	H <sup>+</sup> V-ATPase	H <sup>+</sup> V-ATPase
Phosphorylated intermediate	Glycolytic enzymes (cytoplasm)	Ca <sup>2+</sup> P-ATPase	Na <sup>+</sup> /K <sup>+</sup> P-ATPase H <sup>+</sup> /K <sup>+</sup> P-ATPase

Fig. 4. In animals, a primary Na<sup>+</sup>/K<sup>+</sup> P-ATPase in plasma membranes of single cells and in basolateral membranes of epithelial cells sets up Na<sup>+</sup> electrochemical gradients which lower cell [Na<sup>+</sup>], thereby creating Na<sup>+</sup> electrochemical gradients across the apical membranes that drive secondary transporters. Proton electrochemical gradients are generated by H<sup>+</sup> V-ATPases across plasma membranes of phagocytes and osteoclasts as well as apical plasma membranes of many 'mitochondria-rich' epithelial cells of insects and other animals. AA, amino acid.

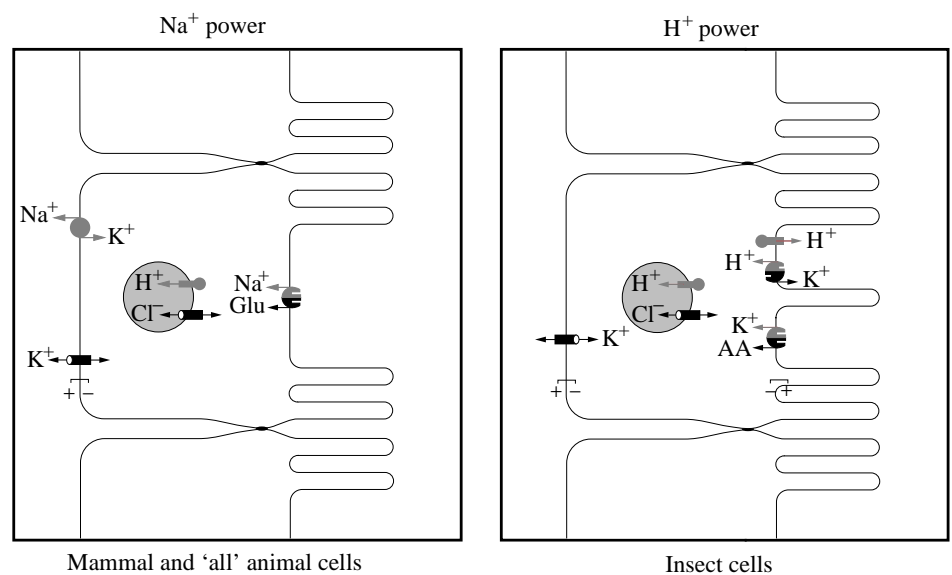

electrochemical gradients for transport work (Harold, 1986). In covalent systems of these organisms, ATP synthesis *via* phosphointermediates (e.g. during glycolysis) and P-type ATPases form H<sup>+</sup> and Na<sup>+</sup> gradients for transport work. Animal plasma membranes strike the sole dissonant chord. Na<sup>+</sup>-linked covalent energization, not H<sup>+</sup>-coupled chemiosmotic energization, is dominant in animal plasma membranes. The Na<sup>+</sup> paradigm is rock solid. Dean's (1941) Na<sup>+</sup> pump, Hodgkin and Huxley's (1952) resting and action potentials and Skou's (1957) isolated Na<sup>+</sup>/K<sup>+</sup>-ATPase, together with thousands of studies on vertebrate nerve, muscle, kidney, intestine and red blood cells and other animal cells and tissues, turned the Na<sup>+</sup> paradigm into the Na<sup>+</sup> dogma. But, are there no exceptions to this dogma, no remnants of the elsewhere-prominent, proton-centered scheme, in animal plasma membranes?

#### Proton energization of animal plasma membranes

Yes, there were exceptions to the Na<sup>+</sup> paradigm from the outset. Insect Malpighian tubules are energized by K<sup>+</sup>, not Na<sup>+</sup> (Ramsay, 1953). The isolated lepidopteran midgut, leached of its small amount of Na<sup>+</sup>, can still pump K<sup>+</sup> for hours (Harvey and Nedergaard, 1964). Insect salivary glands (Berridge *et al.* 1976) and Malpighian tubules (for a review, see Maddrell, 1991) use the K<sup>+</sup> pump to drive fluid secretion. Insect sensory

ensilla use the K<sup>+</sup> pump to generate the receptor potential (for a review, see Thurm and Küppers, 1980). K<sup>+</sup> pump particles, portasomes (Harvey, 1980), are visible in electron micrographs of apical membranes in orthopteran rectum (Gupta and Berridge, 1966) and lepidopteran midgut (Anderson and Harvey, 1966); they are remarkably like the particles studding the membranes of the proton-secreting epithelia of vertebrates (Brown *et al.* 1987). The insect K<sup>+</sup> pump generates a 240 mV gradient that depends moment to moment upon oxygen uptake (Wood *et al.* 1969; Dow and Peacock, 1989). The K<sup>+</sup> pump is insensitive to ouabain – the tissue does not even bind this cardiac glycoside (Jungreis and Vaughan, 1977). Using the presence of portasomes as an assay, the K<sup>+</sup>-pump-containing goblet cell apical membrane (GCAM) was isolated (Cioffi and Wolfersberger, 1983; for a review, see Harvey *et al.* 1983) and K<sup>+</sup>-stimulated ATPase activity was localized overwhelmingly in vesicles from GCAM (Wieczorek *et al.* 1986). Clearly, Na<sup>+</sup> is replaced by K<sup>+</sup> in these insect epithelia.

But do protons play any role? The 10000-fold proton gradient across *M. sexta* midgut GCAM (Dow, 1984) was found to be balanced by a voltage of -240 mV (Dow and Peacock, 1989), leaving no net proton electrochemical gradient; could the voltage that sustains this pH gradient be generated by a perverse proton pump, whose output side is

alkaline? Wiczorek and coworkers provided an astonishing ‘yes’ to that question. When the K<sup>+</sup>-stimulated ATPase in purified GCAM was solubilized, it turned out to be a V-ATPase (Schweickl *et al.* 1989). This conclusion, based on the ATP stimulation of GCAM vesicle acidification as well as on the substrate and inhibitor specificity and the migration of its subunits on gels, has been confirmed overwhelmingly by the high identity of its sequenced subunits with those of other V-ATPases (for reviews, see Wiczorek, 1992; Merzendorfer *et al.* 1997). But perhaps the enzyme is a K<sup>+</sup> V-ATPase; a Na<sup>+</sup> V-ATPase has been identified in *Enterococcus hirai* (e.g. Kakinuma and Igarashi, 1994), so a V-ATPase that pumps K<sup>+</sup> rather than H<sup>+</sup> would not be completely out of the question. Harvey *et al.* (1981, 1983) had long ago postulated such an enzyme, on the basis of electrical, structural and thermodynamic resemblances between the K<sup>+</sup> pump and mitochondrial F-ATPase. The GCAM enzyme turned out to be an H<sup>+</sup> V-ATPase (Schweickl *et al.* 1989); moreover, it turned out to be the primary part of the K<sup>+</sup> pump; the secondary part was a novel K<sup>+</sup>/nH<sup>+</sup> antiporter (Wiczorek *et al.* 1991; for a review, see Lepier *et al.* 1994). The key finding in this astounding development was that acidified GCAM vesicles are alkalized upon addition of K<sup>+</sup> to ATP-free preparations. Moreover, the ATPase activity could be inhibited independently of the antiporter by bafilomycin and the antiporter could be inhibited independently of the ATPase by amiloride. Immunocytochemical labelling demonstrated that the primary part of the ‘K<sup>+</sup> pump’ in other insect tissues was also a V-ATPase (Klein, 1992).

Recently, Küppers and Bunse (1996) have re-invoked the K<sup>+</sup> V-ATPase hypothesis after showing that the receptor current in cockroach sensory sensilla is not affected by the antiporter inhibitors amiloride and harmaline. Such resistance to antiporter inhibitors might be explained by the failure of inhibitors to reach their binding site on the antiporter at effective concentrations *in vivo*. They suggested that mutations might transform a proton-translocating V-ATPase into a K<sup>+</sup>-translocating V-ATPase. Such a transformation is highly unlikely because Dow *et al.* (1992) found that the *M. sexta* proteolipid is virtually identical with known H<sup>+</sup> V-ATPase proteolipids. To alter the *Escherichia coli* F-ATPase so that Li<sup>+</sup> inhibited H<sup>+</sup> transport required the mutation of four residues (Zhang and Fillingame, 1995); even after this extensive change, Na<sup>+</sup> did not inhibit H<sup>+</sup> transport and the transport of neither Li<sup>+</sup> nor Na<sup>+</sup> was demonstrated. Finally, Küppers and Bunse (1996) asserted that driving K<sup>+</sup>/nH<sup>+</sup> antiport with the voltage generated by an adjacent H<sup>+</sup> V-ATPase violates the Second Law of Thermodynamics.

Their thermodynamic analysis was complicated by their use of an energy expression that treats entropy (*S*) as a variable:

$$\Delta G_{ATP/m} = (\Psi^o - \Psi^i)z_k F + RT \ln(a_k^o/a_k^i) + T\Delta S^*, \quad (1)$$

where  $\Delta S^*$  denotes  $\Delta S$  per mole of ATP times the stoichiometric factor *m*,  $\Psi$  is the electrical potential,  $z_k$  is the valence, including sign, of ionic species *k*, *F* is Faraday’s constant,  $a_k^i$  and  $a_k^o$  are the activities of ionic species *k* in the

input and output compartments, respectively, *R* is the gas constant and *T* is the absolute temperature. However, entropy is treated as a constant, with temperature as the variable, in the expression for partial molar free energy, i.e. the Gibb’s chemical potential  $\mu_i$  (Gibbs, 1876). Thus:

$$G \equiv U + PV - TS, \quad (2)$$

where *G* is the Gibbs free energy function, *U* is the internal energy, *P* is the pressure and *V* is the volume. The equation for internal energy is:

$$dU = TdS - PdV + \sum \mu_i |_{S,V,n_j} dn_i, \quad (3)$$

in which entropy is treated as a variable and where the chemical potential is  $\sum \mu_i |_{S,V,n_j} dn_i$ . Differentiating the Gibbs equation:

$$dG = dU + PdV + VdP - TdS - SdT, \quad (4)$$

then solving for *dU* and substituting into equation 3 yields:

$$dG = -SdT + VdP + \sum \mu_i |_{S,V,n_j} dn_i, \quad (5)$$

which reveals why the Gibbs free energy is so useful (Snell *et al.* 1965). It is convenient to hold the temperature and pressure constant, so the troublesome entropy and volume terms can be ignored and the partial molar free energy,  $\mu_i$ , of a substance, *i*, expressed in moles, *n<sub>i</sub>*, and, holding concentrations of other ions, *n<sub>j</sub>*, constant is:

$$\mu_i = \partial G / \partial n_i |_{T,P,n_j}. \quad (6)$$

It is relatively easy to show, after adding a term for the effect of the electrical field,  $zF\Psi$ , and integrating, that the useful expression for the electrochemical potential of an ionic species,  $\bar{u}_k$ , is:

$$\bar{u}_k = u_k^o + RT \ln[k] + zF\Psi, \quad (7)$$

where  $u_k^o$  is the standard chemical potential for *k*. The point is that we only need to know the concentration gradient,  $\Delta[k]$ , and voltage gradient,  $\Delta\Psi$ , to determine which ion movements across a membrane are thermodynamically possible and need not enter into confusing discussions regarding entropy. Nevertheless, whether  $SdT=0$  (Gibbs) or  $T\Delta S^*=0$  (Küppers and Bunse), all agree that  $(\Psi^o - \Psi^i)z_k F + RT \ln(a_k^o/a_k^i)$  cannot exceed  $\Delta G_{ATP/m}$ . However, it does not follow that an H<sup>+</sup> V-ATPase ‘will render the output side both more positive and more acidic’; the entire free energy can appear entirely as a pH gradient, a voltage gradient or any combination of the two, so long as the sum does not exceed  $\Delta G_{ATP/m}$ . Despite these objections to the Küppers and Bunse analysis, the K<sup>+</sup> V-ATPase hypothesis is an attractive alternative to the ‘H<sup>+</sup> V-ATPase, K<sup>+</sup>/nH<sup>+</sup> antiporter’ hypothesis that should be considered as a possibility in future experimental approaches.

The viability of the H<sup>+</sup> V-ATPase, K<sup>+</sup>/2H<sup>+</sup> antiporter hypothesis requires that the V-ATPase be highly selective for H<sup>+</sup> over K<sup>+</sup>, because the intracellular H<sup>+</sup> activity may be 10<sup>-7</sup> mol l<sup>-1</sup> while the intracellular K<sup>+</sup> activity is approximately 10<sup>-1</sup> mol l<sup>-1</sup>. In the *M. sexta* midgut, the selectivity of the pump must be more than 10<sup>6</sup> times greater for H<sup>+</sup> than for K<sup>+</sup>. Such a high selectivity ratio is not unusual for proton pumps, since

Table 1. *Distribution of plasma membrane H<sup>+</sup> V-ATPases*

Location	Function	Reference
Mammalia		
Kidney proximal tubule and collecting duct	Bicarbonate secretion, intracellular pH regulation	1
Epididymis	Tubule acidification	2
Phagocytes	Intracellular pH regulation	3
Osteoclasts	Bone resorption	4
Corneal epithelium	Intracellular pH regulation	5
Placental brush border	Energization of cotransport	6
Thyroid cell line	Intracellular pH regulation	7
Monoamine neurons	Uptake of acidic metabolites	8
Human tumor cells	Intracellular pH regulation	9
Neuroblastoma cells	Maintaining resting potential	10
Intraphepatic bile duct epithelia	H <sup>+</sup> secretion into periductular fluid	11
Hippocampal astrocytes	Intracellular pH regulation	12
Aves		
Chick osteoclasts	Bone resorption	13
Chick chorioallantoic membrane	Intracellular pH regulation	14
Reptilia		
Turtle bladder	H <sup>+</sup> secretion	15
Amphibia		
Frog skin	Uptake of Na <sup>+</sup>	16
Frog taste cells	Intracellular pH regulation	17
Pisces		
Trout gills	Na <sup>+</sup> uptake, H <sup>+</sup> excretion	18
Mollusca		
Freshwater clam mantle epithelium	Acid secretion to shell	19
Crustacea		
<i>Eriocheir sinensis</i> (crab) gills	Na <sup>+</sup> -independent Cl <sup>-</sup> absorption	20
Insecta		
Lepidopteran midgut	Energization of active transport	21
Malpighian tubules	Active cation secretion	22
Lepidopteran sensory sensilla	Receptor current	23
Locust hindgut	H <sup>+</sup> secretion, proline uptake	24
Cockroach salivary glands	Energization of salivation	25
Lepidopteran ovarian follicles	Not known	26
<i>Rhodnius prolixus</i> oocytes	Membrane potential	27
Protozoa		
<i>Entamoeba histolytica</i>	Not known	28

References: (1) S. Gluck, S. Kelly and Q. Al-Awqati (1982). *J. Biol. Chem.* **257**, 9230; (2) D. Brown, B. Lui, S. Gluck and I. Sabolic (1992). *Am. J. Physiol.* **263**, C913; (3) C. J. Swallow, S. Grinstein and O. D. Rotstein (1988). *J. Biol. Chem.* **263**, 19558; (4) H. C. Blair, S.

L. Teitelbaum, R. Ghiselli and S. Gluck (1989). *Science* **245**, 855; (5) V. Torres-Zamorano, V. Ganapathy, M. Sharawy and P. Reinach (1992). *Exp. Eye Res.* **55**, 269; (6) B. J. Simon, P. Kulanthavel, G. Burckhardt, S. Ramamoorthy, F. H. Leibach and V. Ganapathy (1992). *Biochem. J.* **287**, 423; (7) D. J. Woods, J. Soden and S. P. Bidey (1992). *J. Molec. Endocr.* **8**, 79; (8) J. K. Miyamoto, E. Uezu, P.-J. Jiang and A. T. Miyamoto (1993). *Physiol. Behav.* **53**, 65; (9) R. Martinez-Zaguilan, R. M. Lynch, G. M. Martinez and R. J. Gillies (1993). *Am. J. Physiol.* **265**, C1015; (10) V. Gérard, B. Rouzsaire-Dubois and J.-M. Dubois (1994). *Membr. Biol.* **137**, 119; (11) O. Villanger, T. Veel and M. G. Ræder (1993). *Am. J. Physiol.* **265**, G719; (12) C. A. Pappas and B. R. Ransom (1993). *Glia* **9**, 280; (13) R. Baron, L. Neff, W. Brown, D. Louvard and P. J. Courtoy (1990). *J. Cell Sci.* **97**, 439; (14) R. Narbaitz, B. Bastani, N. J. Galvin, V. K. Kapal and D. Z. Levine (1995). *J. Anat.* **186**, 245; (15) S. Gluck, S. Kelly and Q. Al-Awqati (1982). *J. biol. Chem.* **257**, 9230; (16) I. Lacoste, E. Brochiero and J. Ehrenfeld (1993). *J. Membr. Biol.* **134**, 197; (17) Y. Okada, T. Miyamoto and T. Sato (1992). *J. exp. Biol.* **162**, 23; (18) H. Lin, D. C. Pfeiffer, A. W. Vogl, J. Pan and D. J. Randall (1994). *J. exp. Biol.* **195**, 169; (19) R. Hudson (1993). *Am. J. Physiol.* **264**, R946; (20) H. Onken and M. Putzenlechner (1995). *J. exp. Biol.* **198**, 767; (21) H. Schweikl, U. Klein, M. Schindlbeck and H. Wiczorek (1989). *J. Biol. Chem.* **264**, 11136; (22) S. W. Nicolson (1993). *J. Insect Physiol.* **39**, 451; (23) U. Klein and B. Zimmermann (1991). *Cell Tiss. Res.* **266**, 265; (24) U. Klein, M. Timme, F. J. S. Novak, A. Lepier, W. R. Harvey and H. Wiczorek (in preparation); (25) F. Just and B. Walz (1994). *Cell Tiss. Res.* **278**, 161; (26) I. Janssen, K. Hendrickx, U. Klein and A. De Loof (1995). *Archs Insect Biochem. Physiol.* **28**, 131; (27) M. J. O'Donnell and R. K. Sharda (1994). *Physiol. Zool.* **67**, 7; (28) T. Bakker-Grunwald (1992). *J. exp. Biol.* **172**, 311.

all H<sup>+</sup>-transporting V-ATPases transport H<sup>+</sup> in the presence of a high intracellular [K<sup>+</sup>]. High H<sup>+</sup> selectivity is also required for the K<sup>+</sup>/H<sup>+</sup> exchange P-ATPase in the vertebrate stomach or the H<sup>+</sup> F-ATP synthase, both of which are driven by H<sup>+</sup> in the presence of excess K<sup>+</sup>. Wiczorek *et al.* (1991) have shown that, in the presence of amiloride when K<sup>+</sup>/H<sup>+</sup> antiport is inhibited, the V-ATPase pumps H<sup>+</sup> at an activity of 10<sup>-8</sup> mol l<sup>-1</sup>, even in the presence of K<sup>+</sup> at an activity of 2×10<sup>-2</sup> mol l<sup>-1</sup>. In this case, the selectivity is greater than 10<sup>6</sup>. In short, there is no *a priori* argument against the H<sup>+</sup> V-ATPase, K<sup>+</sup>/2H<sup>+</sup> antiporter hypothesis.

The list of animal plasma membranes that are energized by protons is long and growing rapidly (Table 1). On the basis of the physiological, biochemical and molecular evidence reviewed above, the lepidopteran midgut is energized by protons. Based mainly upon labelling with fluorescent antibodies to V-ATPase subunits and/or bafilomycin sensitivity, not only insect midguts (Schweikl *et al.* 1989) but also salivary glands (Just and Walz, 1994), rectum (U. Klein, M. Timme, F. J. S. Novak, A. Lepier, W. R. Harvey and H. Wiczorek, in preparation), Malpighian tubules (Zhang *et al.* 1994) and sensory sensilla (Klein and Zimmermann, 1991) are all energized by protons. Based mainly upon physiology, protein biochemistry, molecular biology and immunocytochemistry, vertebrate kidney and urinary bladder (for a review, see Gluck *et al.* 1992), epididymis (Brown *et al.*

1992; for a review, see Brown and Breton, 1996), phagocytes (for a review, see Grinstein *et al.* 1992), osteoclasts (Vaananen *et al.* 1990; for a review, see Chatterjee *et al.* 1992) and even frog skin (for a review, see Ehrenfeld and Klein, 1997) all contain specialized cells with plasma membranes energized by H<sup>+</sup> V-ATPases. In fact, a pattern is emerging – it is usually the apical plasma membrane of epithelial cells that is energized by protons – just as it is usually the basolateral plasma membrane that is energized by sodium ions. Apparently, animal plasma membranes are not exceptions to the proton paradigm – there is ample proton coupling in animal plasma membranes as well as in plasma membranes of other living organisms. The regulation of V-ATPases is reviewed by Merzendorfer *et al.* (1997) and by Dow *et al.* (1997).

#### *Medical and agricultural significance of the proton paradigm*

The proton energization of specific apical plasma membranes presents both clinical and industrial opportunities. Although some cancer cell plasma membranes are energized by H<sup>+</sup> V-ATPases, it probably is not worthwhile to focus on the nearly ubiquitous V-ATPase itself for clinical intervention. More promising are specific channels and H<sup>+</sup>-linked porters in these proton-energized membranes. Also promising are the special conditions, such as extreme acidity or alkalinity surrounding the membranes, that can be exploited to activate targeted control agents.

It is relatively easy to obtain pharmacological and cytological evidence that a membrane is energized by an H<sup>+</sup> V-ATPase. The specific V-ATPase inhibitors bafilomycin and concanamycin (for a review, see Drose and Altendorf, 1997) are commercially available. Fluorescent antibodies to V-ATPase subunits can be obtained for immunocytochemistry (Klein, 1992). Finally, the V<sub>1</sub> domains of the V<sub>1</sub>V<sub>0</sub> ATPase are likely to appear as portosomes, which are visible in electron micrographs (for a review, see Harvey, 1992).

#### **Redox regulation of H<sup>+</sup> V-ATPase activity and targeting**

##### *Targeting of H<sup>+</sup> V-ATPases to plasma membrane and endomembranes*

What is the mechanism by which H<sup>+</sup> V-ATPases are targeted to the plasma membrane in some cases and to endomembranes, such as lysosomes, in other cases? Differential targeting would seem to imply that plasma membrane and endomembrane H<sup>+</sup> V-ATPases differ in structure within a single cell (Merzendorfer *et al.* 1997). An alternative explanation might be that a single form of the ATPase is carried by membrane cycling between plasma membranes and endomembranes (e.g. Lacoste *et al.* 1993). This explanation implies that H<sup>+</sup> V-ATPases are present in plasma membranes as well as in endomembranes of all eukaryotic cells. The presence of an H<sup>+</sup> V-ATPase is implied in any plasma membrane that undergoes endocytosis and

produces early endosomes which contain H<sup>+</sup> V-ATPases. This recycling hypothesis is illustrated in Fig. 5 (modified from Forgac, 1992; Mellman, 1992). The hypothesis is complicated at its inception by the argument of Mellman's group (Fuchs *et al.* 1994) that acidifying H<sup>+</sup> V-ATPases are not likely to be present in early endosomes and the finding by Sabolic *et al.* (1992) that early endosomes are labeled only by antibodies to the B subunit. However, M. Forgac (personal communication) has countered with evidence that early endosomes are also labelled by antibodies to the A subunit.

If early endosomes contain H<sup>+</sup> V-ATPase, even in an inactive form, then the following hypothesis for differential targeting is viable (Fig. 5). In the 'constitutive exocytotic' pathway (green arrows) simplified from Forgac (1992), secretory vesicles with H<sup>+</sup> V-ATPases and Cl<sup>-</sup> channels bud off from the *trans*-Golgi. They fuse with the apical plasma membrane and discharge their contents to the exterior, leaving behind H<sup>+</sup> V-ATPases and Cl<sup>-</sup> channels in the plasma membrane. As ligands bind to receptors on the plasma membrane, clathrin-coated pits form and the inactive H<sup>+</sup> V-ATPases, closed Cl<sup>-</sup> channels and ligand-receptor complexes are pinched off as non-acidified, clathrin-coated vesicles which soon lose their coat to become early endosomes. Binding of V-ATPase to the vesicles is thought to be mediated by a 50 kDa subunit of the AP-2 adaptin complex (Myers and Forgac, 1993). The early endosomes fuse with the membrane of the compartment for uncoupling receptor and ligand (CURL) where the V-ATPase is activated, the Cl<sup>-</sup> channels open and provide CURL with additional acidifying capacity to release the ligands from receptors. Finally, vesicles, containing ATPases and channels, bud off from CURL and return to the apical plasma membrane. This pathway implies that at least small numbers of V-ATPase and Cl<sup>-</sup> channels are always present in apical plasma membranes, although they may be inactive there. The existence of pinocytotic vesicles containing H<sup>+</sup> V-ATPase would also imply the constitutive presence of this enzyme in the plasma membrane. However, a new question arises: what turns on V-ATPases in the cell interior and turns them off in the plasma membrane?

##### *Sulfhydryl groups regulate V-ATPase activity*

Feng and Forgac (1994) have focused attention on Cys254 of the catalytic subunit A in coated-vesicle H<sup>+</sup> V-ATPase. This residue is in the consensus sequence, GXGKTV, that is found in many nucleotide-binding proteins (Walker *et al.* 1984) and is near the triphosphate portion of ATP in the tertiary structure of the enzyme. They propose a novel mechanism for regulation of vacuolar acidification in which Cys254 is oxidized and forms a disulfide bond with Cys532 that inactivates the enzyme. Similar 'redox modulation' has been proposed for the human glutamate transporter (Trotti and Hediger, 1996). We propose that oxidizing conditions are likely around many plasma membranes and that the enzyme would be inactivated there. However, in the cell interior, where reducing conditions are

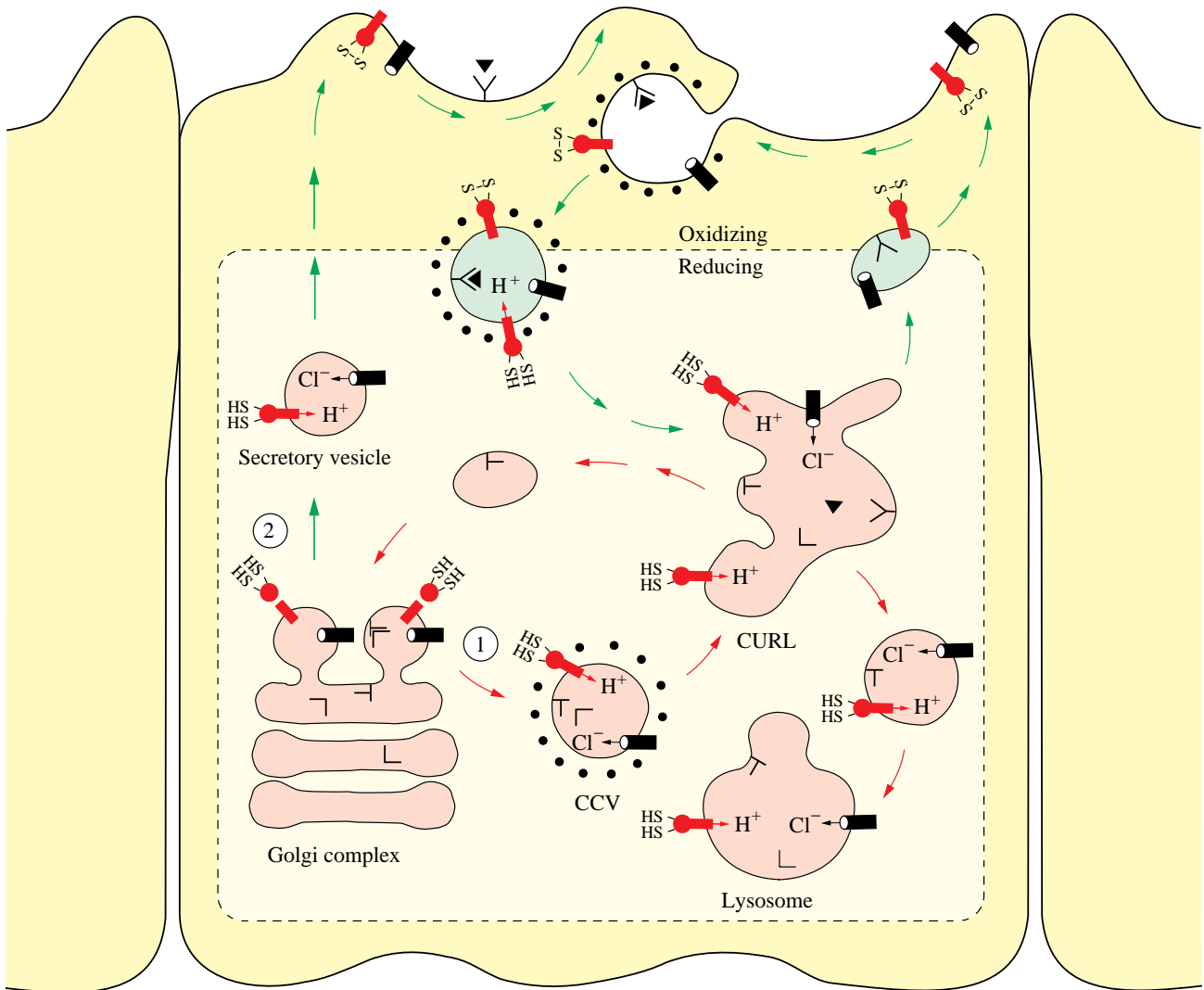

- ① Endomembrane pathway
- ② Plasma membrane pathway

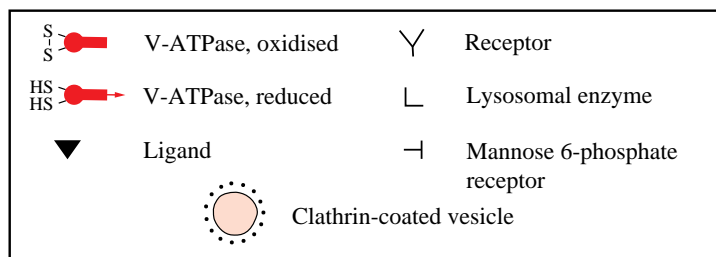

Fig. 5. (1) Cycling of V-ATPase- and mannose 6-phosphate receptor-containing membrane from the *trans*-Golgi to the compartment for uncoupling receptor and ligand (CURL) and back to the Golgi complex, with a path to lysosomes, is well accepted. (2) Cycling of V-ATPase-containing membrane *via* secretory vesicles to the plasma membrane and thence to the endocytotic-exocytotic pathway is controversial. Plasma membrane V-ATPases must be present in all cells in which this pathway exists. Green, neutral; pink, acidic; yellow, oxidizing environment; light yellow, reducing environment.

maintained by agents such as glutathione, the critical cysteine residues would be reduced, the constraining disulfide bond would be broken and the enzyme would be activated (see also Merzendorfer *et al.* 1997). The implication that if H<sup>+</sup>-V-

ATPase-containing endosomes bud off from animal plasma membrane then V-ATPases must be ubiquitous, albeit inactive, constituents of animal plasma membranes has so far been overlooked.



*Evolution of H<sup>+</sup> F-ATP synthases and H<sup>+</sup> V-ATPases from an A-ATPase-like ancestor*

The presence of ubiquitous, constitutive plasma membrane V-ATPases is consistent with current views regarding their evolution (Nelson, 1989). On the basis of an analysis of the distribution of highly conserved sequences in H<sup>+</sup> A-ATPases of present-day archaeobacteria, H<sup>+</sup> F-ATP synthases from mitochondria and H<sup>+</sup> V-ATPases from yeast vacuoles, Nelson and Taiz (1989), Ihara *et al.* (1992), Bakker-Grunwald (1992) and others propose that all three present-day enzymes derive from an A-ATPase-like common ancestor.

The key event in this divergence of H<sup>+</sup> V-ATPases from H<sup>+</sup> F-ATP synthases is thought to be the introduction of oxygen into the atmosphere by cyanobacteria. H<sup>+</sup> V-ATPases, with their inactivating disulfide bridge involving Cys254 of the ATP binding site, could not function in the oxidizing environment at the plasma membrane. Mutants lacking this regulatory cysteine are thought to have initiated the H<sup>+</sup> F-ATP synthase line, starting with plasma membrane H<sup>+</sup> F-ATP synthases of bacterial plasma membranes. Thus, H<sup>+</sup> V-ATPases would be selected against in bacteria where, indeed, they are seldom, if ever, found. But in all eukaryotes the friendly, reducing atmosphere of the cytoplasm would allow H<sup>+</sup> V-ATPases to remain active and survive. Finally, since there would be a selective advantage in retaining the secretory pathway that targets them to the plasma membranes, H<sup>+</sup> V-ATPases would remain there as constitutive but inactive components, to be activated upon demand.

*Cytochrome oxidase as a reducing agent – mitochondria-rich cells*

The plasma membranes of macrophages and the ‘apical’ plasma membranes of their cousins the osteoclasts probably reside under conditions as reducing as those deep within cells – it is not surprising that their plasma membrane H<sup>+</sup> V-ATPases are active. The apical plasma membranes of many epithelial cells likewise probably face reducing conditions, e.g. the lumen of insect Malpighian tubules. Particularly striking are the many ‘mitochondria-rich’ cells that are now known to contain active H<sup>+</sup> V-ATPases on their apical plasma membranes, e.g. the columnar cells of insect Malpighian tubules (Beams *et al.* 1955), the goblet cells of lepidopteran larvae (Anderson and Harvey, 1966) and the trichogen and tormogen cells of insect sensory sensilla (for a review, see Thurm and Küppers, 1980). Mitochondria-rich cells have been described in many renal tissues and even in frog skin. Most recently, they have been described in epididymis (Breton *et al.* 1996; for a review, see Brown *et al.* 1997). All of these mitochondria-rich cells are heavily studded with portosomes (Harvey, 1980), the visible manifestation of the V<sub>1</sub> domain of H<sup>+</sup> V-ATPases, on their apical membranes (for a review, see Brown and Breton, 1996). The usual explanation for the mitochondria-richness of these cells is that it provides abundant ATP for the dense arrays of H<sup>+</sup> V-ATPases. However, in goblet cells of posterior caterpillar midgut, mitochondria are not adjacent to the apical membrane (Cioffi,

1979), yet this region transports K<sup>+</sup> as well as the anterior regions (Cioffi and Harvey, 1981), where mitochondria and plasma membrane are exquisitely intimate.

An alternative explanation for the mitochondria-richness may be the capacity of cytochrome oxidase to remove oxygen from the environment of nearby plasma membrane V-ATPases. Chance (1957) has shown that this enzyme has such a high affinity for oxygen that it remains fully oxidized at oxygen concentrations as low as 4 μmol l<sup>-1</sup> (Fig. 6). This property means that mitochondria can continue undiminished ATP production while creating the oxygen-poor environment that would allow plasma membrane H<sup>+</sup> V-ATPases to remain active. The intimacy of H<sup>+</sup>-F-ATP-synthase-containing mitochondrial inner membranes and H<sup>+</sup>-V-ATPase-containing plasma membranes reaches shocking proportions in lepidopteran midgut (Cioffi, 1979) and in insect Malpighian tubules where mitochondria move into microvilli upon activation (Bradley and Satir, 1981). These two tissues hold world records, respectively, for the magnitude of the short-circuit current (2 mA cm<sup>-2</sup>; for a review, see Harvey and Zerahn, 1972) and fluid secretion rate (one-third of the cell volume per minute; for a review, see Maddrell, 1991).

**ΔΨ as a driver of antiport and symport**

*H<sup>+</sup> V-ATPase always generates ΔΨ, with the input side negative*

If two aqueous compartments are separated by a membrane that is ideally impermeable to all ions, including protons, and if an H<sup>+</sup> V-ATPase is inserted into the membrane, then the hydrolysis of added ATP would merely separate H<sup>+</sup> from A<sup>-</sup>, where A<sup>-</sup> is an anion, across the membrane. There would be no net H<sup>+</sup> or A<sup>-</sup> flux and therefore no pH change in the output compartment. Assuming ideal coupling between pump and ATP hydrolysis, ΔΨ was estimated to be 240 mV for the

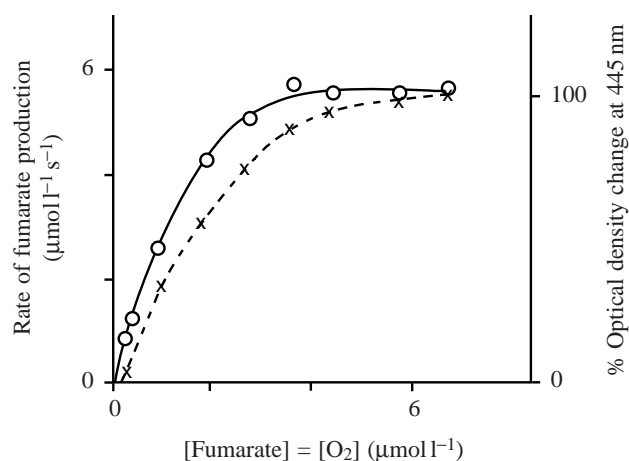

Fig. 6. The oxygen saturation of cytochrome oxidase (×) is deduced from the rate of fumarate production (○). Redrawn from Chance (1957). ‘The oxygen affinity of the respiratory system is so high that no changes of rate will occur until the oxygen concentration has fallen to about 4 μmol l<sup>-1</sup> at 25 °C’.

lepidopteran midgut, using data supplied by Mandel *et al.* (1980); this value was calculated from the relationship,  $\Delta\Psi = \Delta G_{ATP}/2F = RT/2F(\ln K_e/Q)$ , where  $RT/2F \approx 30$  mV at 25 °C and  $K_e/Q$  is the products-to-reactants concentration ratio at equilibrium/actual conditions (Harvey, 1992). In the presence of a  $Cl^-$  channel,  $Cl^-$  would follow the  $H^+$  and the output compartment would be acidified, as in most endomembranes. In lepidopteran midgut, a  $K^+/2H^+$  antiporter is present in the same membrane as the  $H^+$  V-ATPase.  $\Delta\Psi$  drives the pumped proton along with a second proton back into the cell in exchange for a  $K^+$  (Azuma *et al.* 1995). *In vivo* the  $K^+$  activity is held steady at approximately  $140 \text{ mmol l}^{-1}$  on both sides of the membrane, the  $[Na^+]$  being low and also equal on both sides (Dow and Harvey, 1988); the entire energy from the ATP hydrolysis appears as a measured transmembrane voltage of approximately 240 mV (Dow and Peacock, 1989); thus, coupling between  $\Delta G_{ATP}/2F$  and  $\Delta\Psi$  must be almost ideal, as it is in other chemiosmotically coupled processes.

*The voltage component of the proton-motive force is sufficient to drive amino acid:K<sup>+</sup> symport without  $\Delta pH$*

Giordana *et al.* (1982, 1989) identified six amino acid:K<sup>+</sup> symport systems in brush-border membrane vesicles in larval midgut from *Philosamia cynthia* with specificities for neutral amino acids, L-proline, glycine, L-lysine, glutamic acid and D-alanine. In vesicles from larval *M. sexta*, three types of amino acid:K<sup>+</sup> symporter have been identified. (1) A broad-spectrum, zwitterionic amino acid:K<sup>+</sup> symporter, system B (Hennigan *et*

*al.* 1993), was found that resembled the one in *P. cynthia*. A cooperative effort, between Italian and American groups, is under way to clone system B by expressing *M. sexta* poly(A) RNA in *Xenopus laevis* (Castagna *et al.* 1997). (2) A K<sup>+</sup> symporter that accepts either proline or glycine was found in *M. sexta* (Bader *et al.* 1995) rather than the two separate systems of *P. cynthia*. (3) A cationic lysine, arginine:K<sup>+</sup> symporter, system R<sup>+</sup> (Liu and Harvey, 1996) is probably identical with the 'L-lysine' system of *P. cynthia*, but lysine uptake was non-competitively inhibited by arginine in *M. sexta*, as it was in *P. cynthia*, so the system probably transports only cationic arginine *in vivo*. System R<sup>+</sup> has a substrate spectrum almost identical to that of the mammalian cationic amino acid uniporter, y<sup>+</sup>, so probes constructed from y<sup>+</sup> cDNA (MacLeod *et al.* 1992) are being used in an attempt to clone R<sup>+</sup> (D. Feldman, B. Stevens and W. R. Harvey, unpublished results). No specific glutamate:K<sup>+</sup> symporter was found in *M. sexta*; although glutamate was accumulated in response to a K<sup>+</sup> gradient, countertransport accumulation of glutamate was not demonstrable (Xie *et al.* 1994). The voltage alone is thought to drive all of these amino acid:K<sup>+</sup> symporters; thus, the  $V_{max}$  of the symporters for cation is increased with voltage (Giordana and Parenti, 1994; Parthasarathy and Harvey, 1994). Similarly, the voltage alone is thought to drive K<sup>+</sup>/2H<sup>+</sup> antiport across the goblet cell apical membrane *in vivo* (Wieczorek *et al.* 1991).

Although K<sup>+</sup>/2H<sup>+</sup> antiport from the midgut lumen *in vivo* would be difficult because  $[H^+]_{lumen}$  is  $10^{-11} \text{ mol l}^{-1}$ , antiport

Table 2. Nomenclature of solute-translocating membrane proteins

Chemiosmotic ATPase	A cation-translocating ATPase with cytoplasmic (i) and membrane (o) domains and no phosphointermediate; a primary active transporter
H <sup>+</sup> A-ATPase	Chemiosmotic A <sub>1</sub> A <sub>o</sub> ATPase of archaebacterial plasma membrane
H <sup>+</sup> F-ATPase	Chemiosmotic F <sub>1</sub> F <sub>o</sub> ATP synthase-ATPase of bacterial plasma membrane, thylakoid membrane or mitochondrial inner membrane
H <sup>+</sup> V-ATPase	Chemiosmotic V <sub>1</sub> V <sub>o</sub> ATPase of vacuolar or plasma membranes
Na <sup>+</sup> F-ATPase	Chemiosmotic F <sub>1</sub> F <sub>o</sub> ATPase that translocates Na <sup>+</sup> rather than H <sup>+</sup>
Portosome	Approximately 10 nm sphere with stalk in electron micrograph of ATP synthesising-hydrolysing membrane; A <sub>1</sub> , F <sub>1</sub> or V <sub>1</sub> domain of a chemiosmotic ATPase
C <sup>+</sup> /C <sup>+</sup> P-ATPase	Ion-translocating ATPase with a phosphorylated intermediate, e.g. Na <sup>+</sup> /K <sup>+</sup> P-ATPase, H <sup>+</sup> /K <sup>+</sup> P-ATPase; a primary active transporter
Transporter, porter	Membrane protein that bind substrates (S) cations (C <sup>+</sup> ) and/or anions (A <sup>-</sup> ) and translocates them across a membrane; a secondary active transporter
S, C <sup>+</sup> or A <sup>-</sup> uniporter	Passive transporter that facilitates diffusion of substrate, cation or anion across a membrane
S:C <sup>+</sup> or C <sup>+</sup> :C <sup>+</sup> symporter; cotransporter	Secondary active transporter that cotransports a substrate or a cation (also anion) up its electrochemical gradient, driven by movement of a different ion down its electrochemical gradient
C <sup>+</sup> /C <sup>+</sup> antiporter; exchanger	Secondary active transporter that exchanges one cation (also anion) that moves up its electrochemical gradient driven by movement of another ion down its electrochemical gradient
C <sup>+</sup> channel	Water-lined pore through a membrane protein that increases cationic (also anionic) conductance by approximately 10 orders of magnitude over that of lipid bilayer; distinguished from uniporter by inability to mediate countertransport
C <sup>+</sup> pump	Membrane protein(s) postulated from electrical, flux or inhibitor measurements to couple ATP hydrolysis to cation (also anion) translocation; may be a single ATPase (primary active transporter) or (primary) ATPase coupled to a symporter or antiporter (secondary active transporter); the terms pump, primary and secondary transporters are becoming obsolete as transport proteins are identified

from the goblet cavity would be easier because  $[H^+]_{\text{cavity}} \approx 10^{-7} \text{ mol l}^{-1}$ . How can such a low concentration of H<sup>+</sup> drive antiport? The answer is that the antiport is driven by the approximately -240 mV voltage. The effect of voltage is such that every 60 mV at approximately 25 °C approximates a tenfold increase in the effective concentration of the ionic species. Although this explanation is correct thermodynamically, the mind searches for an intuitive explanation of how a voltage can drive transport. Alan Hodgkin offered a suggestion, which is consistent with statistical mechanics diffusion theory – diffusion is like fleas hopping and electrodiffusion is like fleas hopping in a breeze. Thus, fleas that were hopping in a gentle breeze of 0.016 km h<sup>-1</sup> with no voltage would be blasted with a hurricane of 160 km h<sup>-1</sup> (=100 m.p.h.) at a voltage of 240 mV. In other words, the probability of particles hitting the positive side of the membrane would be 10 000 times greater with a voltage of 240 mV than with no voltage, and the effective  $[H^+]_{\text{cavity}}$  would increase to  $10^{-3} \text{ mol l}^{-1}$ . In the *M. sexta* midgut, the high voltage can drive the pump–antiporter couple to an alkalization of 3 pH units (Azuma *et al.* 1995), producing a lumen pH of 11, if the cell pH is 8. In Malpighian tubular lumen and sensory sensillar lymph, where in each case pH ≈ 7, the V-ATPase–antiporter couple would also not face an impossible task. However, the mosquito larval midgut presents a challenge; the lumen pH is approximately 12 (Dadd, 1975) and neither a goblet cavity nor a large  $\Delta\Psi$  has yet been reported.

#### Circuit analysis of complex membrane systems

As immunocytochemistry and molecular biology allow increasingly sophisticated studies on plasma membranes and endomembranes of epithelial cells, the classical, Hodgkin–Huxley analysis of membrane function becomes increasingly limited. In nerve and muscle, miniscule ion fluxes lead to 100 mV changes in membrane potential, whereas in rapidly transporting epithelia, massive ion fluxes are accomplished at constant voltage. Hodgkin and Huxley could view a neuron as a two-compartment system, inside and outside, and needed only to consider two ions, Na<sup>+</sup> and K<sup>+</sup>. By contrast, even the simplest epithelium consists of at least a basal extracellular space, the cell and the apical compartment, as well as several intracellular compartments. Nevertheless, even a complex epithelium is much simpler than, say, the circuit in a modern-day computer or television set. Martin (1992) suggested that the same type of circuit analysis that has been useful in designing computers and televisions would be useful in analysing epithelia. Key aspects of amino acid:K<sup>+</sup> symport and K<sup>+</sup>/nH<sup>+</sup> antiport were simulated using reasonable values from experimental data (Martin and Harvey, 1994). What contribution this adaptation of circuit theory to complex biological systems will make remains to be determined.

### Appendix

#### Membrane transport nomenclature

ATP hydrolysis via H<sup>+</sup>-coupled ATPases yields proton

electrochemical gradients; thus,  $\Delta G_{\text{ATP}}/m = RT \ln([H^+]_i/[H^+]_o) + zF\Delta\Psi = \Delta\bar{\mu}_{H^+}$ , where  $\Delta G_{\text{ATP}}/m$  is the free energy of ATP hydrolysis divided by the number of protons transported per ATP. Dividing by  $F$ , to express the value in volts, and noting that  $z_{H^+} = +1$ , yields  $\Delta G_{\text{ATP}}/mF = RT/F \ln([H^+]_i/[H^+]_o) + \Delta\Psi = \Delta\bar{\mu}_{H^+}/F$ ; Mitchell (1961) called this last term, the proton-motive force or  $\Delta p$ . At 25 °C,  $\Delta G_{\text{ATP}}/F \approx 60 \text{ mV}(\Delta\text{pH}) + \Delta\Psi$ . For example, across the goblet cell apical membrane (GCAM) in *Manduca sexta* larval midgut,  $\Delta G_{\text{ATP}}/F \approx 500 \text{ mV}$  and  $\Delta G_{\text{ATP}}/mF \approx -250 \text{ mV}$  (Mandel *et al.* 1980). Surprisingly, there is little or no pH gradient across GCAM (Chao *et al.* 1991), so  $60 \text{ mV}(\Delta\text{pH}) \approx 0$ , but  $\Delta\Psi$  was found to be approximately -240 mV (Dow and Peacock, 1989). So, in this case, ATP hydrolysis is tightly coupled to the generation of a transmembrane voltage.

When one approaches the broader literature that includes bacteria, yeast and fungi, plants and insects, one feels like Alice when told that 'a word means exactly what I say it means'. Moreover, transporter designations are confusing. Who would guess that the H<sup>+</sup>-ATPase of plant apical membranes is a proton-translocating ATPase with a phosphorylated enzyme in its catalytic cycle and that the V-ATPase of the vacuole is a proton-translocating ATPase that acts with no such phosphoenzyme? A more 'user-friendly' designation scheme is suggested in Table 2. In particular, we follow a suggestion by Peter Maloney (personal communication) that cotransported (symported) solutes should be separated by a colon (:), thus glucose:Na<sup>+</sup> symporter, and that exchanged (antiported) solutes should be separated by a slash (/), thus Na<sup>+</sup>/H<sup>+</sup> antiporter. We also suggest that the convention 'driver/driven' be used if possible. Thus, glucose:Na<sup>+</sup> symport denotes that glucose uptake is driven by Na<sup>+</sup> and K<sup>+</sup>/H<sup>+</sup> antiport denotes that K<sup>+</sup> secretion is driven by H<sup>+</sup>. Since both types of porter operate in either direction, depending upon electrochemical gradients, a great deal of judgement is still involved.

This review was supported in part by research grants from the National Institutes of Health (AI-22444 and AI 30464) to W.R.H. and the Deutsche Forschungsgemeinschaft (Wi 698) and EEC (SCI\*-CT90-0480) to H.W. We thank Daniel J. Harvey for assistance with the art work.

### References

- ANDERSON, E. AND HARVEY, W. R. (1966). Active transport by the *Cecropia* midgut. II. Fine structure of the midgut epithelium. *J. Cell Biol.* **31**, 107–134.
- ANRAKU, Y., UMEMOTO, N., HIRATA, N. AND WADA, Y. (1989). Structure and function of the yeast vacuolar membrane proton ATPase. *J. Bioenerg. Biomembr.* **21**, 589–605.
- AZUMA, M., HARVEY, W. R. AND WIECZOREK, H. (1995). Stoichiometry of K<sup>+</sup>/H<sup>+</sup> antiport helps to explain extracellular pH 11 in a model epithelium. *FEBS Lett.* **361**, 153–156.
- BADER, A. L., PARTHASARATHY, R. AND HARVEY, W. R. (1995). A novel proline, glycine:K<sup>+</sup> symporter in midgut brush-border membrane vesicles from larval *Manduca sexta*. *J. exp. Biol.* **198**, 2599–2607.

- BAKKER-GRUNWALD, T. (1992). Ion transport in parasitic protozoa. *J. exp. Biol.* **172**, 311–322.
- BEAMS, H. W., TAHMISIAN, T. N. AND DIVINE, R. L. (1955). Electron microscope studies on the cells of the Malpighian tubules of the grasshopper. (Orthoptera, Acrididae). *J. biophys. biochem. Cytol.* **1**, 197–202.
- BERNARD, C. (1878/1879). *Leçons sur les Phénomènes de la Vie Communs aux Animaux et aux Végétaux*. Baillere: Paris. Translated by J. F. Fulton. *Selected Readings in the History of Physiology*. Springfield, IL: Charles C. Thomas.
- BERRIDGE, M. J., LINDLEY, B. D. AND PRINCE, W. T. (1976). Studies on the mechanism of fluid secretion by isolated salivary glands of *Calliphora*. *J. exp. Biol.* **64**, 311–322.
- BRADLEY, T. J. AND SATIR, P. (1981). 5-Hydroxytryptamine-stimulated mitochondrial movement and microvillar growth in the lower Malpighian tubule of the insect, *Rhodnius prolixus*. *J. Cell Sci.* **49**, 139–161.
- BRETON, S., SMITH, P. J. S., LUI, B. AND BROWN, D. (1996). Acidification of male reproductive tract by a proton-pumping H<sup>+</sup>ATPase. *Nature Medicine* **2**, 470–472.
- BROWN, D. AND BRETON, S. (1996). Mitochondria-rich, proton-secreting, epithelial cells. *J. exp. Biol.* **199**, 2345–2358.
- BROWN, D., GLUCK, S. AND HARTWIG, J. (1987). Structure of a novel membrane-coating material in proton-secreting epithelial cells and identification as an H<sup>+</sup>ATPase. *J. Cell Biol.* **105**, 1637–1648.
- BROWN, D., LIU, B., GLUCK, S. AND SABOLIC, I. (1992). A plasma membrane proton ATPase in specialized cells of rat epididymis. *Am. J. Physiol.* **263**, C913–C916.
- BROWN, D., SMITH, P. AND BRETON, S. (1997). Role of V-ATPase-rich cells in acidification of the male reproductive tract. *J. exp. Biol.* **200**, 257–262.
- CASTAGNA, M., SHAYAKUL, C., TROTTI, D., SACCHI, V. F., HARVEY, W. R. AND HEDIGER, M. A. (1997). Molecular characteristics of mammalian and insect amino acid transporters: implications for amino acid homeostasis. *J. exp. Biol.* **200**, 269–286.
- CHANCE, B. (1957). Cellular oxygen requirements. *Fedn Proc. Fedn Am. Soc. exp. Biol.* **16**, 671–680.
- CHAO, A. C., MOFFETT, D. F. AND KOCH, A. R. (1991). Cytoplasmic pH and goblet cavity pH in the posterior midgut of the tobacco hornworm (*Manduca sexta*). *J. exp. Biol.* **155**, 403–414.
- CHATTERJEE, D., CHAKRABORTY, M., LEIT, M., NEFF, L., JAMSA-KELLOKUMPU, S., FUCHS, R., BARTKIEWICZ, M., HERNANDO, N. AND BARON, R. (1992). The osteoclast proton pump differs in its pharmacology and catalytic subunits from other vacuolar H<sup>+</sup>ATPases. *J. exp. Biol.* **172**, 193–204.
- CIOFFI, M. (1979). The morphology and fine structure of the larval midgut of the moth (*Manduca sexta*) in relation to active ion transport. *Tissue & Cell* **11**, 467–479.
- CIOFFI, M. AND HARVEY, W. R. (1981). Comparison of potassium transport in three structurally distinct regions of the insect midgut. *J. exp. Biol.* **91**, 103–116.
- CIOFFI, M. AND WOLFERSBERGER, M. G. (1983). Isolation of separate apical, lateral and basal plasma membrane from cells of an insect epithelium. A procedure based on tissue organization and ultrastructure. *Tissue & Cell* **15**, 781–803.
- DADD, R. H. (1975). Alkalinity within the midgut of mosquito larvae with alkaline-active digestive enzymes. *J. Insect Physiol.* **21**, 1847–1853.
- DEAN, R. B. (1941). Theories of electrolyte equilibrium in muscle. *Biol. Symp.* **3**, 331–348.
- DOW, J. A. T. (1984). Extremely high pH in biological systems: a model for carbonate transport. *Am. J. Physiol.* **246**, R633–R635.
- DOW, J. A. T., DAVIES, S. A., GUO, Y., GRAHAM, S., FINBOW, M. AND KAISER, K. (1997). Molecular genetic analysis of V-ATPase function in *Drosophila melanogaster*. *J. exp. Biol.* **200**, 237–245.
- DOW, J. A. T., GOODWIN, S. F. AND KAISER, K. (1992). Analysis of the gene encoding a 16-kDa proteolipid subunit of the vacuolar H<sup>+</sup>ATPase from *Manduca sexta* midgut and tubules. *Gene* **122**, 355–360.
- DOW, J. A. T. AND HARVEY, W. R. (1988). Role of midgut electrogenic K<sup>+</sup> pump potential difference in regulating lumen K<sup>+</sup> and pH in larval Lepidoptera. *J. exp. Biol.* **140**, 455–463.
- DOW, J. A. T. AND PEACOCK, J. M. (1989). Microelectrode evidence for the electrical isolation of goblet cell cavities in *Manduca sexta* middle midgut. *J. exp. Biol.* **143**, 101–114.
- DRÖSE, S. AND ALTENDORF, K. (1997). Bafilomycins and concanamycins as inhibitors of V-ATPases and P-ATPases. *J. exp. Biol.* **200**, 1–8.
- EHRENFELD, J. AND KLEIN, U. (1997). The key role of the H<sup>+</sup> V-ATPase in acid–base balance and Na<sup>+</sup> transport processes in frog skin. *J. exp. Biol.* **200**, 247–256.
- FENG, Y. AND FORGAC, M. (1994). Inhibition of vacuolar H<sup>+</sup>ATPase by disulfide bond formation between Cysteine 254 and Cysteine 532 in subunit A. *J. Biol. Chem.* **269**, 13224–13230.
- FILLINGAME, R. H. (1997). Coupling H<sup>+</sup> transport and ATP synthesis in F<sub>1</sub>F<sub>0</sub> ATP synthases: glimpses of interacting parts in a dynamic molecular machine. *J. exp. Biol.* **200**, 217–224.
- FORGAC, M. (1992). Structure, function and regulation of the coated vesicle V-ATPase. *J. exp. Biol.* **172**, 155–169.
- FUCHS, R., ELLINGER, A., PAVELEKA, M., MELLMAN, I. AND KLAPPER, H. (1994). Rat liver endocytic coated vesicles do not exhibit ATP-dependent acidification *in vitro*. *Proc. natn. Acad. Sci. U.S.A.* **91**, 4811–4815.
- GIBBS, J. W. (1876). *Collected Works*, vol. I. New Haven, CT: Yale University Press.
- GIORDANA, B. AND PARENTI, P. (1994). Determinants for the activity of the neutral amino acid/K<sup>+</sup> symport in lepidopteran larval midgut. *J. exp. Biol.* **196**, 145–155.
- GIORDANA, B., SACCHI, F. V. AND HANOZET, G. M. (1982). Intestinal amino acid absorption in lepidopteran larvae. *Biochim. biophys. Acta* **692**, 81–88.
- GIORDANA, B., SACCHI, V. F., PARENTI, P. AND HANOZET, G. M. (1989). Amino acid transport systems in intestinal brush border membranes from lepidopteran larvae. *Am. J. Physiol.* **257**, R494–R500.
- GLUCK, S. L., NELSON, R. D., LEE, B. S., WANG, Z.-Q., GUO, X.-L., FU, J.-Y. AND ZHANG, K. (1992). Biochemistry of the renal V-ATPase. *J. exp. Biol.* **172**, 219–229.
- GRINSTEIN, S., NANDA, A., LUKACS, G. AND ROTSTEIN, O. (1992). V-ATPase in phagocytic cells. *J. exp. Biol.* **172**, 179–192.
- GUPTA, B. L. AND BERRIDGE, M. J. (1966). A coat of repeating subunits on the cytoplasmic surface of the plasma membrane in the rectal papillae of the blowfly, *Calliphora erythrocephala* (Meig.) studied *in situ* by electron microscopy. *J. Cell Biol.* **29**, 376–382.
- HAROLD, F. M. (1986). *The Vital Force*. New York: W. H. Freeman Co. 577pp.
- HARVEY, W. R. (1980). Water and ions in the gut. In *Insect Biology in The Future 'VBW 80'* (ed. M. Locke and D. S. Smith), pp. 105–124. New York: Academic Press.

- HARVEY, W. R. (1992). Physiology of the V-ATPases. *J. exp. Biol.* **172**, 1–17.
- HARVEY, W. R., CIOFFI, M., DOW, J. A. T. AND WOLFERSBERGER, M. G. (1983). Potassium ion transport ATPase in insect epithelia. *J. exp. Biol.* **106**, 91–117.
- HARVEY, W. R., CIOFFI, M. AND WOLFERSBERGER, M. G. (1981). Portosomes as coupling factors in active transport and oxidative phosphorylation. *Am. Zool.* **21**, 775–791.
- HARVEY, W. R. AND NEDERGAARD, S. (1964). Sodium-independent active transport of potassium in the isolated midgut of the *Cecropia* silkworm. *Proc. natn. Acad. Sci. U.S.A.* **51**, 757–765.
- HARVEY, W. R. AND ZERAHN, K. (1972). Active transport of potassium and other alkali metals by the isolated midgut of the silkworm. In *Current Topics in Membranes and Transport*, vol. 3 (F. Bronner and A. Kleinzeller), pp. 367–410. London, New York: Academic Press.
- HEDIGER, M. A. (1994). Structure, function and evolution of solute transporters in prokaryotes and eukaryotes. *J. exp. Biol.* **196**, 15–49.
- HENNIGAN, B. B., WOLFERSBERGER, M. G. AND HARVEY, W. R. (1993). Neutral amino acid symport in larval *Manduca sexta* brush border membrane vesicles deduced from cation dependent uptake of leucine, alanine and phenylalanine. *Biochim. biophys. Acta* **1148**, 216–222.
- HILLE, B. (1992). *Ionic Channels of Excitable Membranes*, 2nd edn. Sunderland, MA: Sinauer Ass. 607pp.
- HODGKIN, A. L. AND HUXLEY, A. F. (1952). A quantitative description of membrane current and its application to conduction and excitation in nerve. *J. Physiol., Lond.* **117**, 500–544.
- IHARA, K., ABE, T., SUGIMUR, A. K. I. AND MUKOHATA, Y. (1992). Halobacterial A-ATP synthase in relation to V-ATPase. *J. exp. Biol.* **172**, 475–485.
- JUNGREIS, A. M. AND VAUGHAN, G. L. (1977). Insensitivity of lepidopteran tissues to ouabain: absence of ouabain binding and Na<sup>+</sup>-K<sup>+</sup> ATPases in larval and adult midgut. *J. Insect Physiol.* **23**, 503–509.
- JUST, F. AND WALZ, B. (1994). Immunocytochemical localization of Na<sup>+</sup>/K<sup>+</sup>-ATPase and V-H<sup>+</sup>-ATPase in the salivary gland of the cockroach, *Periplaneta americana*. *Cell Tissue Res.* **278**, 161–170.
- KAKINUMA, Y. AND IGARASHI, K. (1989). Sodium-translocating adenosine triphosphatase in *Streptococcus faecalis*. *J. Bioenerg. Biomembr.* **21**, 679–692.
- KAKINUMA, Y. AND IGARASHI, K. (1994). Purification and characterization of the catalytic moiety of vacuolar-type Na<sup>+</sup>-ATPase from *Enterococcus hirae*. *J. Biochem., Tokyo* **116**, 1302–1308.
- KLEIN, U. (1992). The insect V-ATPase, a plasma membrane proton pump energizing secondary active transport: immunological evidence for the occurrence of a V-ATPase in insect ion-transporting epithelia. *J. exp. Biol.* **172**, 345–354.
- KLEIN, U. AND ZIMMERMANN, B. (1991). The vacuolar-type ATPase from insect plasma membrane: immunocytochemical localization in insect sensilla. *Cell Tissue Res.* **266**, 265–273.
- KÜPPERS, J., AND BUNSE, I. (1996). A primary cation transport by a V-type ATPase of low specificity. *J. exp. Biol.* **199**, 1327–1334.
- LACOSTE, I., BROCHIERO, E. AND EHRENFELD, J. (1993). Control of Na<sup>+</sup> and H<sup>+</sup> transports by exocytosis/endocytosis phenomena in a tight epithelium. *J. Membr. Biol.* **134**, 197–212.
- LEPIER, A., AZUMA, M., HARVEY, W. R. AND WIECZOREK, H. (1994). K<sup>+</sup>/H<sup>+</sup> antiport in the tobacco hornworm midgut: the K<sup>+</sup> component of the K<sup>+</sup> pump. *J. exp. Biol.* **196**, 361–373.
- LIU, Z. AND HARVEY, W. R. (1996). Arginine uptake through a novel cationic amino acid:K<sup>+</sup> symporter, System R<sup>+</sup>, in brush border membrane vesicles from larval *Manduca sexta* midgut. *Biochim. biophys. Acta* **1282**, 25–31.
- MACLEOD, C. L., FINLEY, K. D. AND KAKUDA, D. K. (1992). y<sup>+</sup>-type cationic amino acid transport: expression and regulation of the mCAT genes. *J. exp. Biol.* **196**, 109–121.
- MADDRELL, S. H. P. (1991). The fastest fluid-secreting cell known: the upper Malpighian tubule cell of *Rhodnius*. *BioEssays* **13**, 357–362.
- MANDEL, L. J., MOFFETT, D. F., RIDDLE, T. G. AND GRAFTON, M. M. (1980). Coupling between oxidative metabolism and active transport in the midgut of tobacco hornworm. *Am. J. Physiol.* **238**, C1–C9.
- MARTIN, F. G. (1992). Circuit analysis of transmembrane voltage relationships in V-ATPase-coupled ion movements. *J. exp. Biol.* **172**, 387–401.
- MARTIN, F. G. AND HARVEY, W. R. (1994). Ionic circuit analysis of K<sup>+</sup>/H<sup>+</sup> antiport and amino acid/K<sup>+</sup> symport energized by a proton-motive force in *Manduca sexta* larval midgut vesicles. *J. exp. Biol.* **196**, 77–92.
- MELLMAN, I. (1992). The importance of being acid: the role of acidification in intracellular membrane traffic. *J. exp. Biol.* **172**, 39–45.
- MERZENDORFER, H., GRÄF, R., HUSS, J., HARVEY, W. R. AND WIECZOREK, H. (1997). Regulation of proton-translocating V-ATPases. *J. exp. Biol.* **200**, 225–235.
- MITCHELL, P. (1961). Coupling of phosphorylation to electron and hydrogen transfer by a chemiosmotic type of mechanism. *Nature* **191**, 144–148.
- MYERS, M. AND FORGAC, M. (1993). The coated vesicle vacuolar (H<sup>+</sup>)-ATPase associates with and is phosphorylated by the 50-kDa polypeptide of the clathrin assembly protein AT-2. *J. biol. Chem.* **268**, 9184–9186.
- NELSON, N. (1989). Structure, molecular genetics and evolution of vacuolar H<sup>+</sup>-ATPases. *J. Bioenerg. Biomembr.* **21**, 553–571.
- NELSON, N. AND TAIZ, L. (1989). The evolution of H<sup>+</sup>-ATPases. *Trends Biol. Sci.* **14**, 113–116.
- PARTHASARATHY, R. AND HARVEY, W. R. (1994). Potential differences influence amino acid/Na<sup>+</sup> symport rates in larval *Manduca sexta* midgut brush-border membrane vesicles. *J. exp. Biol.* **189**, 55–67.
- RAMSAY, J. A. (1953). Active transport of potassium by the Malpighian tubules of insects. *J. exp. Biol.* **30**, 358–369.
- SABOLIC, I., WUARIN, F., SHI, L.-B., VERKMAN, A. S., AUSIELLO, D. A., GLUCK, S. AND BROWN, D. (1992). Apical endosomes isolated from kidney collecting duct principal cells lack subunits of the proton pumping ATPase. *J. Cell Biol.* **119**, 111–122.
- SCHWEIKL, H., KLEIN, U., SCHINDLBECK, M. AND WIECZOREK, H. (1989). A vacuolar-type ATPase, partially purified from potassium-transporting plasma membranes of tobacco hornworm midgut. *J. biol. Chem.* **264**, 11136–11142.
- SKOU, J. C. (1957). The influence of some cations on an adenosine triphosphatase from peripheral nerves. *Biochim. biophys. Acta* **23**, 394–401.
- SNELL, F. M., SHULMAN, S., SPENCER, R. P. AND MOOS, C. (1965). *Biophysical Principles of Structure and Function*. Reading, MA: Addison-Wesley. 390pp.
- SZE, H., WARD, J. M., LAI, S. AND PERERA, I. (1992). Vacuolar-type H<sup>+</sup>-translocating ATPases in plant endomembranes: subunit organization and multigene families. *J. exp. Biol.* **172**, 123–135.

- THURM, U. AND KÜPPERS, J. (1980). Epithelial physiology of insect sensilla. In *Insect Biology in the Future 'VBW 80'* (ed. M. Locke and D. S. Smith), pp. 735–764. New York: Academic Press.
- TROTTI, D. AND HEDIGER, M. (1996). Redox sensing properties of a human neuronal glutamate transporter. *Annual Meeting, Society for Neuroscience*, Washington, DC, Nov. 16–21, 1996 (abstract).
- VAANANEN, H. K., KARHUKORPI, E. K., SUNDQUIST, K., ROININEN, I., HENTUNEN, T., TUUKKANEN, J. AND LAKKAKORPI, P. (1990). Evidence for the presence of a proton pump of the vacuolar H<sup>+</sup>ATPase type in the ruffled borders of osteoclasts. *J. Cell Biol.* **111**, 1305–1311.
- WALKER, J. E., SARASTE, M. AND GAY, N. J. (1984). The *unc* operon. Nucleotide sequence, regulation and structure of ATP-synthase. *Biochim. biophys. Acta* **768**, 164–200.
- WIECZOREK, H. (1992). The insect V-ATPase, a plasma membrane proton pump energizing secondary active transport: molecular analysis of electrogenic potassium transport in the tobacco hornworm midgut. *J. exp. Biol.* **172**, 335–343.
- WIECZOREK, H., PUTZENLECHNER, M., ZEISKE, W. AND KLEIN, U. (1991). A vacuolar-type proton pump energizes K<sup>+</sup>/H<sup>+</sup>-antiport in an animal plasma membrane. *J. biol. Chem.* **266**, 15340–15347.
- WIECZOREK, H., WOLFERSBERGER, M. G., CIOFFI, M. AND HARVEY, W. R. (1986). Cation-stimulated ATPase in purified membranes from tobacco hornworm midgut. *Biochim. biophys. Acta* **857**, 271–281.
- WOOD, J. L., FARRAND, P. S. AND HARVEY, W. R. (1969). Active transport of potassium by the Cecropia midgut. VI. Microelectrode potential profile. *J. exp. Biol.* **50**, 169–178.
- XIE, T., PARTHASARATHY, R., WOLFERSBERGER, M. G. AND HARVEY, W. R. (1994). Anomalous glutamate/alkali cation symport in larval *Manduca sexta* midgut. *J. exp. Biol.* **194**, 181–194.
- ZHANG, S., LEYSSENS, A., VAN KERKHOVE, E., WELTENS, R., VAN DRIESSCHE, W. AND STEELS, P. (1994). Electrophysiological evidence for the presence of an apical H<sup>+</sup>-ATPase in Malpighian tubules of *Formica polyctena*: intracellular and luminal pH measurements. *Pflügers Arch.* **426**, 288–295.
- ZHANG, Y. AND FILLINGAME, R. H. (1995). Changing the ion binding specificity of the *Escherichia coli* H<sup>+</sup> transporting ATP synthase by directed mutagenesis of subunit c. *J. biol. Chem.* **270**, 87–93.