

DYNAMIC GEARING IN RUNNING DOGS

DAVID R. CARRIER*, COLIN S. GREGERSEN AND NATALIE A. SILVERTON

Department of Biology, University of Utah, 257 South 1400 East, Salt Lake City, UT 84112-0840, USA

*e-mail: carrier@biology.utah.edu

Accepted 10 September; published on WWW 10 November 1998

Summary

Dynamic gearing is a mechanism that has been suggested to enhance the performance of skeletal muscles by maintaining them at the shortening velocities that maximize their power or efficiency. We investigated this hypothesis in three domestic dogs during trotting and galloping. We used ground force recordings and kinematic analysis to calculate the changes in gear ratio that occur during the production of the external work of locomotion. We also monitored length changes of the vastus lateralis muscle, an extensor muscle of the knee, using sonomicrometry in four additional dogs to determine the nature and rate of active shortening of this muscle. During both trotting and galloping, the gear ratios of the extensor muscles of the elbow, wrist and ankle joints were relatively constant early in limb support, but decreased rapidly during the second half of support. The gear ratio at the hip exerted an extensor moment initially, but decreased throughout limb support and became negative midway

through support. This pattern of decreasing gear ratio during the second half of support indicates that dynamic gearing does not maximize muscle power or efficiency at the elbow, wrist, hip and ankle joints. In contrast, the extensor muscles of the shoulder and knee joints exhibited an increase in gear ratio during limb support. In two dogs, the vastus lateralis muscle shortened at a relatively constant rate of 3.7–4 lengths s⁻¹ during intermediate-speed galloping. This pattern of increasing gear ratio and constant velocity of muscle shortening at the knee joint is consistent with the hypothesis of dynamic gearing. Given the amount of work done at the knee and shoulder joints of running dogs, dynamic gearing may contribute to the economy of constant-speed running and may be important to integrated limb function.

Key words: mechanical advantage, gear ratio, locomotion, muscle, muscle performance, sonomicrometry, dog, trotting, galloping.

Introduction

Morphologists and physiologists have long recognized that synergistic muscles often have different mechanical advantages around joints and have therefore suggested that different muscles use different gears (Hildebrand, 1995; Rome *et al.* 1988). Mechanical advantage around joints has also been shown to vary with body size (Alexander *et al.* 1981; Biewener, 1982, 1983, 1989) and during ontogeny (Carrier, 1996a). A muscle's leverage may also change during a period of activity, such as a locomotor cycle (Carrier *et al.* 1994). Such dynamic gearing would influence the force and velocity of muscle shortening.

Dynamic changes in gear ratio could conceivably improve the contractile performance of a muscle. Because the force that a skeletal muscle can produce declines in a hyperbolic manner as shortening velocity increases (Fenn and Marsh, 1935; Hill, 1938), there is an intermediate range of muscle shortening velocities at which the mechanical power and energetic efficiency of a muscle are maximized (Hill, 1950). Consequently, dynamic gearing could help to maintain muscles at their optimal shortening velocity for efficiency or power during a running or jumping step by changing the ratio of muscle shortening velocity to ground velocity. Take, for

example, an animal accelerating forward during a step. If an extensor muscle were to start the step with a low gear ratio and end the step with a high gear ratio, the shortening of the muscle could be maintained at the optimal velocity for power or efficiency as the animal's ground speed increased. Thus, dynamic gearing could reduce the need for locomotor specialization, allowing individuals to move more efficiently, accelerate more quickly, run faster and jump higher.

It has been suggested that dynamic gearing enhances the performance of the ankle extensor muscles of running and accelerating humans (Carrier *et al.* 1994). In that study, force plate and kinematic analyses of running steps showed low gear ratios at touch-down and an increase in gear ratio throughout the contact phase, with the highest ratio at take-off. Although the gear ratio of the ankle extensor muscles changed in the right direction to facilitate optimal shortening of the muscles, the study did not monitor the actual shortening of the muscles, so the question remains as to whether the change in gear ratio was beneficial to muscle performance. Additionally, the ankle extensor muscles of humans may contract isometrically to store and recover energy in their series elastic components during constant-speed running (Cavagna *et al.* 1964, 1977; Alexander, 1988; Farley *et al.* 1991;

Roberts *et al.* 1997). In this case, dynamic gearing would not enhance the contractile performance of the muscle.

To test further the hypothesis of dynamic gearing, we measured changes in the gear ratio around the limb joints of three domestic dogs during trotting and galloping. The hypothesis of dynamic gearing would be falsified for a particular joint if the gear ratio of that joint did not increase during the portion of limb support in which the joint underwent extension. If changes in gear ratio at a particular joint were found to be appropriate to optimize muscle contraction, we then asked whether enough work was done by that joint during running (Gregersen *et al.* 1998) to make dynamic gearing significant. Additionally, in the case of the knee joint, we measured the rate and magnitude of active shortening of the vastus lateralis muscle using sonomicrometry to determine whether the muscle shortened and whether the rate of shortening matched the expected rate for peak efficiency.

Materials and methods

Ground forces and joint kinematics

Single-limb ground forces and joint kinematics were measured in three dogs during rapid trotting and fast galloping. The dogs were of mixed breed (labrador cross, pointer cross and mongrel), under 5 years of age and in good physical condition (for details, see Table 1). The subjects ran down a carpeted track-way, 50 m long, with a force plate (Kistler, 9281B SN; 0.4 m × 0.6 m) located mid-track and mounted flush with the track floor. To obtain observations on trotting, individual dogs were led on a leash by a human runner who set the pace. In the galloping trials, all three dogs ran in series down the track. The lead dog pursued a tennis ball, and the other two dogs chased the lead dog.

Only trials in which a dog ran at relatively constant speed over the force plate were analyzed. Different methods were employed to determine constancy of locomotion speed in trotting and galloping trials. To identify constant-speed trials during trotting, we compared the sum of the positive horizontal ground forces from a forelimb and subsequent hindlimb with

the sum of the negative horizontal forces from these limbs. A trial was not used if there was a difference of more than 20% between the sums of the positive and negative horizontal forces. To identify galloping trials in which a dog ran at a constant speed, the horizontal (forward *versus* backward) accelerations were measured using a linear accelerometer (Endevco, model 7290A), mounted on the dog's back, or a series of photocells spaced at 2 m intervals along the length of the track was used to monitor speed. Percentage differences in acceleration or speed between strides were determined, and trials in which there was a change in acceleration between strides of more than 20% or a change in speed of more than 10% were rejected.

Ground forces were sampled at 1000 Hz using an analog-to-digital acquisition and analysis system (BioPac Systems, Inc.). The position of the limb joints as the dog moved over the force plate was monitored using video at 120 images s⁻¹ (Peak Performance Inc.). The force and video recordings were synchronized using a synchronization circuit that marked the video images and supplied a voltage to the digitizing system at the start of every second video image (Peak Performance Inc.).

Calculation of gear ratios

The length of the ground reaction force moment arms of the different joints was determined by calculating the orthogonal distance from the vector of the ground reaction force to the axis of rotation of each joint (Biewener and Full, 1992). This method measures the moment arms that are employed in the production of the external work of locomotion. These are the moment arms that must be addressed to evaluate the hypothesis of dynamic gearing. The hypothesis states that changes in gearing will allow a muscle to contract at a velocity that maximizes its power or efficiency. It is the external moment arm of the muscle that it must work through to apply displacement and velocity to the center of mass of the animal. Thus, it is this external moment arm that determines the rate at which a muscle must shorten to apply a given amount of power to the center of mass. Moments due to the mass, inertia and acceleration of the limb segments can increase or decrease the forces that muscles must generate, but they do not change the rate at which muscles must shorten

Table 1. Sample sizes, mean running velocities and Froude number for the three dogs used in the analysis of gear ratio

Dog	Mass (kg)	Gait	Forelimb		Hindlimb		Froude number
			<i>N</i>	Mean velocity (m s ⁻¹)	<i>N</i>	Mean velocity (m s ⁻¹)	
A	29.2	Trot	5	3.23±0.11	5	3.23±0.11	1.40
		Gallop	7	8.30±0.18	9	8.03±0.56	3.47
B	24.9	Trot	4	3.20±0.28	4	3.20±0.28	1.40
		Gallop	6	8.79±0.45	7	8.04±0.81	3.53
C	25.0	Trot	6	2.97±0.12	6	2.97±0.12	1.41
		Gallop	12	6.94±1.42	7	7.16±0.76	3.40

Velocities are presented as means ± s.d.

Froude number = $u/(gL)^{0.5}$, where u is forward velocity, g is the acceleration due to gravity and L is the length of the hindlimb at mid-support (Farley *et al.* 1993).

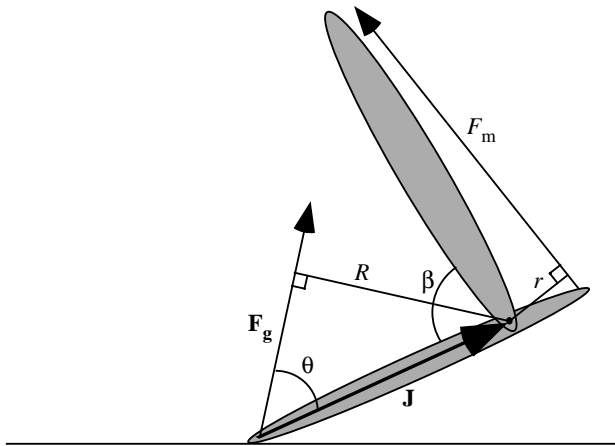

Fig. 1. Schematic diagram of the shank and foot of a dog, illustrating the method used to calculate the length of the lever arms of the ground reaction force (R). \mathbf{F}_g , ground reaction force vector; \mathbf{J} , joint vector; θ , angle between the ground reaction force vector and the joint vector; F_m , muscle force vector; r , muscle moment arm; β , joint angle.

to produce a given amount of external power. Therefore, the moments associated with the changes in internal energy of the limbs are not relevant to the question of dynamic gearing and they were not measured in this study.

To calculate the ground reaction force moment arms, the origin of the ground reaction force under the dog's foot (center of pressure) was determined from the force recordings (Fig. 1). The ground reaction force vector (\mathbf{F}_g) and joint vector (\mathbf{J}), defined as the distance between the center of pressure and the joint, were crossed to yield the angle (θ) between them. The magnitude of the joint vector ($|\mathbf{J}|$) was then used as the hypotenuse of a right-angled triangle to calculate the moment arm R from the equation:

$$R = |\mathbf{J}| \sin \theta.$$

The muscle moment arm (r) was measured as the perpendicular distance from the joint's center of rotation to the line of applied force from the muscle (F_m). This was measured directly for each joint from the dogs as they rested with the joint in flexed (90° for elbow and ankle) and fully extended positions. Values of the muscle moment arm for intermediate joint angles (β) were interpolated by assuming that the length of the moment arm changed in a linear manner from fully flexed to fully extended joint angles. Thus, an independent value for the length of the muscle moment arm was calculated for each observed joint angle during the period of support.

Gear ratio is the out-lever divided by the in-lever. The gear ratio was determined for the extensor muscles of the shoulder, elbow, wrist, hip, knee and ankle joints for each dog during both trotting and galloping. By convention, a positive gear ratio indicates an extensor moment and a negative gear ratio indicates a flexor moment. The switch from a positive to a negative gear ratio, or *vice versa*, occurs when the ground reaction force vector passes through the joint. The sample sizes

and mean velocities for each dog and gait are given in Table 1. To obtain mean values of gear ratio from trials with slightly different contact times, the data were normalized and the results are presented as a percentage of limb support.

The gear ratio depends upon the length of both the ground reaction force moment arm (R) and the muscle moment arm (r). Nevertheless, the results of our analysis indicate that changes in the ground reaction force moment arm play the dominate role in determining how gear ratio changes during the support phase. This is because, during support, r changed by a relatively small proportion of its maximum length, whereas R varied between zero at some point during support and several times the maximum length of r during other portions of support. Because R underwent a much greater change in relative length than did r , small errors in the measurement of the length of r had little effect on the calculated gear ratio and almost no effect on the pattern of change in gear ratio. It is the pattern of change that provides a test of the hypothesis of dynamic gearing, and errors in the measurement of r did not influence this pattern.

The shoulder joint (scapulo-humeral joint) represented more of a problem for analysis than the other joints because of difficulty in locating the position of the joint and scapula in our video recordings. Because the skin in this region moves independently of the musculo-skeletal system, it is not possible to rely on external skin markers to monitor joint position. Consequently, for the calculation of gear ratios around the shoulder, we used our best guess of the location of the shoulder joint from the video recordings. To determine the changes in angle between the scapula and humerus, we relied on cineradiographic recordings, donated by Dr Dennis Bramble and Dr Farrish Jenkins, from three other dogs. Nevertheless, the difficulty in locating the position of the shoulder and in determining changes in joint angle require us to have less confidence in the data presented for the shoulder joint than for the other joints.

Shortening of the vastus lateralis muscle

Changes in the length of the vastus lateralis muscle were measured using sonomicrometry in four additional dogs as they trotted and galloped on a motorized treadmill. Masses, running speeds and Froude numbers for the dogs used in this analysis are listed in Table 2. The four dogs were a small dalmatian (D in Table 2), a mongrel (E), a German shorthaired pointer (F), and a labrador retriever/basenji cross (G).

Table 2. Mass, running speeds and Froude numbers of the dogs used in the sonomicrometry recordings

Dog	Mass (kg)	Trotting	Galloping		
		speed (m s^{-1})	Froude number	speed (m s^{-1})	Froude number
D	23	3.04	1.56	5.37	2.75
E	17	3.09	1.57	6.08	3.09
F	21	3.41	1.65	6.02	2.91
G	16			5.37	2.70

The dogs were trained to trot and gallop comfortably on the treadmill prior to surgery. Subjects were initially anesthetized with an intravenous injection of sodium thiopental. They were then intubated with an endotracheal tube and maintained on a ventilator with room air and 1–2% Halothane. An incision 4 cm long was made in the skin of the thigh over the belly of the vastus lateralis muscle. A second incision was made in the fascia lata to expose the muscle. Two sets of cylindrical sonomicrometry transducers (CY 5-2, Triton Technology, Inc.) and associated electromyographic electrodes were then sutured into the muscle. The sonomicrometry transducers had been prepared previously by gluing each one to a steel mounting pin, which allowed the transducer to be sutured in place (Olson and Marsh, 1998). Small holes for each transducer were made in the muscle using a blunt probe, and the mounting pins of the transducers were sutured to the fascia of the muscle. Each set of transducers was oriented along the length of the muscle fibers and positioned 12–19 mm apart. The two sets of transducers were placed 3–4 cm apart. The use of two sets of transducers increased the likelihood that we would obtain reliable recordings and, when both sets worked, provided an indication of regional heterogeneity within the muscle.

Implanted with each set of sonomicrometry transducers was an electromyographic electrode. These electrodes were the sew-through type, and were constructed and implanted as described previously (Betts *et al.* 1979; Carrier, 1996b). Each electrode was implanted parallel and approximately 3–6 mm lateral to its set of transducers. Lead wires from the electrodes and transducers were fed subcutaneously to a dorsal exit point just caudal to the dorsal tips of the scapulae. At the exit point, the wires passed through a silastic tube that was sutured to the skin. The tube was then filled with silicone sealant which provided a mechanical anchor for the wires and a barrier to pathogens. The dogs were given 2 days to recover from surgery. They were then allowed to trot and gallop on the treadmill while we recorded the electrical activity and changes in length of the vastus lateralis muscle and monitored foot-fall using a video recorder. After completion of the recordings, the transducers and electrodes were removed and the dogs were adopted as pets.

Sonomicrometry and electromyographic signals were passed through shielded, lightweight cables (Cooner Wire Inc.) to amplifiers. The sonomicrometry signals were processed with sonomicrometer modules (model 201; Triton Technology, Inc.), and the electromyographic signals were filtered above 1000 Hz and below 100 Hz, and amplified 5000 or 10 000 times using Grass P5 AC amplifiers. The signals were sampled at 2500 Hz with an analog-to-digital acquisition and analysis system (BioPac Systems, Inc.) and stored on a Macintosh computer.

Active shortening and speed of shortening were measured during the period in which the muscle was thought to exert force on the ground. This period of force generation was determined from two criteria: (1) the moment of the muscle had to be positive, and (2) the muscle was assumed to produce force for no longer than 60 ms after the end of the electrical activity in the muscle. To determine when the muscle moment was positive, we used the mean result from the recordings of ground forces

from the three other dogs that we ran over the force plate. During trotting in these dogs, the moment of the extensor muscle of the knee became positive early in support at approximately 25% of the support phase. During galloping, the muscle moment became positive at approximately 37% of support. Thus, if in the sonomicrometry recordings the muscle was observed to shorten after 25% (trot) or 37% (gallop) of the support period, we assumed that the knee was extending and counted the shortening as active. Although it may not always have been true that the beginning of shortening corresponded to the beginning of knee extension, a review of our video recordings indicates that the two events generally occurred almost simultaneously. The degree to which the muscle shortened actively during this period and the rate at which it shortened were calculated relative to the length of the muscle during quiet standing. We refer to the length of the muscle during standing as the resting length. Means and standard deviations of percentage changes in length and the rate of shortening were calculated from a sample of 10 strides for each dog.

Results

Gearing and joint excursion during running

Although the three dogs ran at slightly different mean speeds, the Froude numbers within a gait were comparable among dogs (Table 1). This indicates that the dogs ran at speeds that were kinematically similar for their body size (Alexander, 1983) and justifies our averaging of the gear ratio data from the three dogs.

Patterns of change in the gear ratio during a running step were similar during both trotting and galloping (Figs 2, 3). The gear ratios of the extensor muscles of the wrist, elbow and ankle were positive during most of the support phase, but gradually decreased to become negative during the latter portion of support. The decrease in gear ratio around these joints appeared to occur slightly more rapidly in the gallop than in the trot, and the gear ratios may have been slightly higher in the gallop than in the trot, but these differences were not statistically significant. The wrist was distinctive during trotting because its gear ratio remained nearly constant for the first two-thirds of support. The gear ratio of the ankle was also relatively constant during the first half of support. In contrast, the gear ratio of the elbow extensor muscles decreased at a roughly constant rate to become negative at 70–80% of the support phase. The gear ratio of the extensor muscles of the hip also began with positive values, but decreased rapidly and became negative at or before mid-support (Figs 2, 3). Thus, the extensor muscles of the hip

Fig. 2. Gear ratios of the extensor muscles (solid lines) and joint angles (broken lines) plotted as a function of contact time (limb support) during trotting. (A) Sample data from a stride of a 29 kg dog trotting at 3.2 m s^{-1} . (B) Means and standard deviations of the data from three dogs plotted relative to the percentage of the support phase. Sample sizes and running speeds are listed in Table 1. Gear ratios greater than zero represent positive extensor muscle moments. Declining joint angles indicate flexion of a joint.

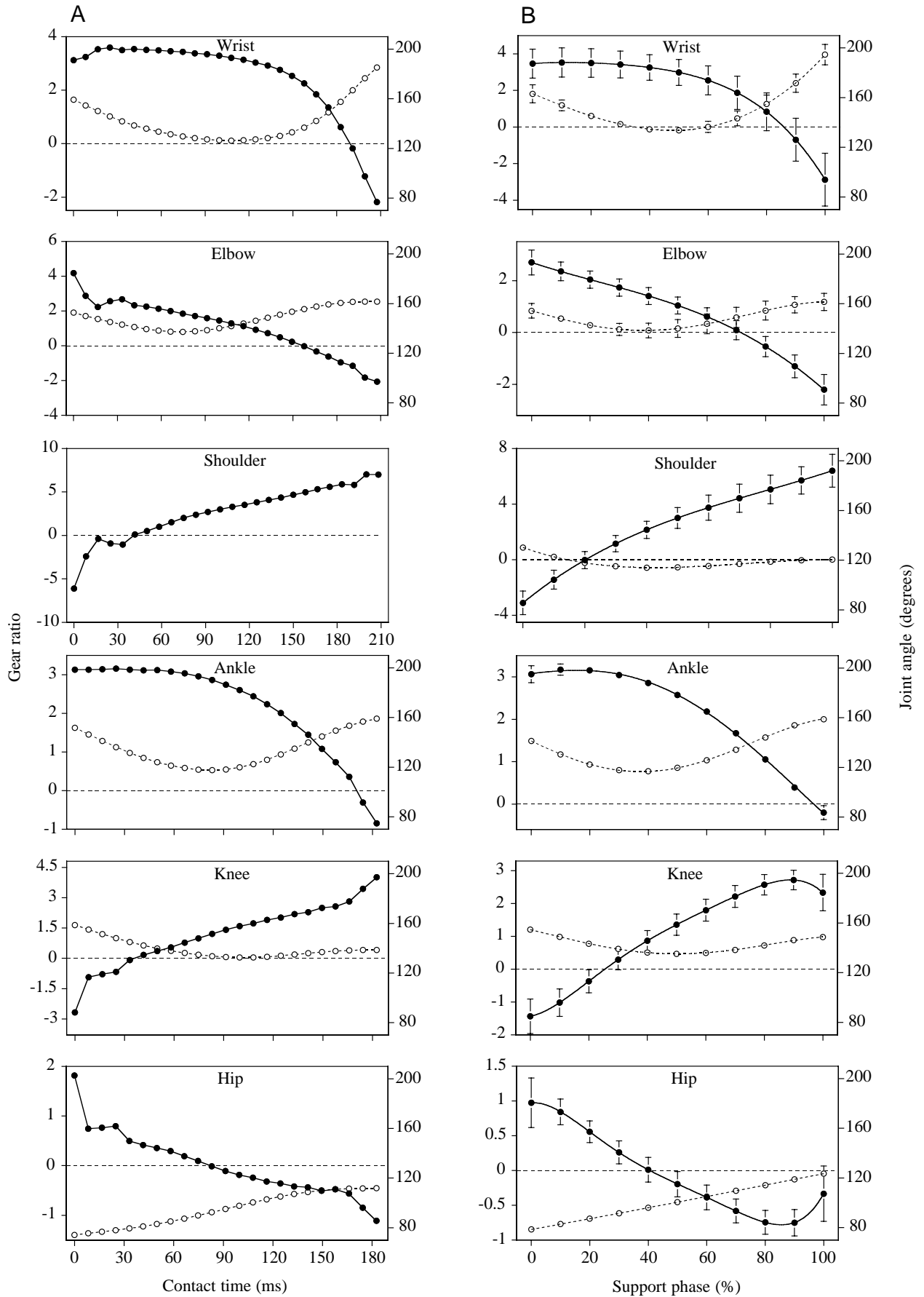

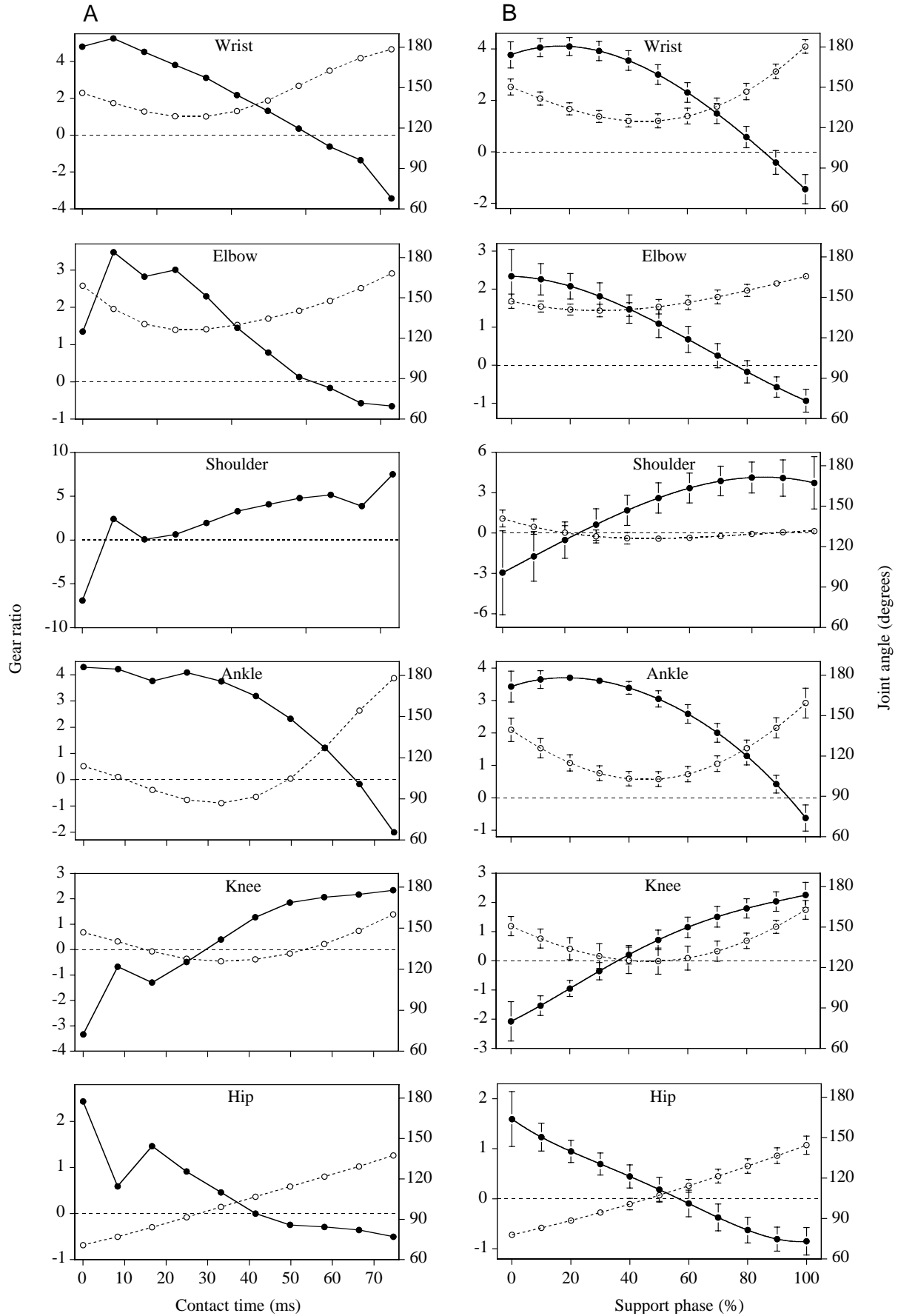

Fig. 3. Gear ratios of the extensor muscles (solid lines) and joint angles (broken lines) plotted as a function of contact time (limb support) during galloping. (A) Sample data from a stride of a 29 kg dog galloping at approximately 8 ms^{-1} . (B) Means and standard deviations of the data from three dogs plotted relative to the percentage of the support phase. Sample sizes and running speeds are listed in Table 1. Other details are as in Fig. 2.

operated with a positive ground reaction force moment during only the first half of limb support.

The gear ratio of the extensor muscles of the knee and shoulder displayed a pattern that was roughly the opposite of that observed at the other joints (Figs 2, 3). At these joints, the gear ratio was negative at the beginning of support, increased throughout support in an approximately linear fashion, became positive at 20–25% (trotting) or 25–35% (galloping) of support, and reached values of 2–3 (knee) and 4–6 (shoulder) at the end of support. Consequently, the extensor muscles of the knee and shoulder joints exert moments on the ground during the latter two-thirds of support.

Two patterns of joint excursion were observed (Figs 2, 3). The hip displayed only joint extension. The other five joints (wrist, elbow, shoulder, ankle and knee) experienced first flexion and then extension during limb support. In the wrist, elbow, ankle and knee, there was always more extension than flexion. In the shoulder, there was more flexion than extension.

Shortening of the vastus lateralis muscle

Two patterns of active shortening of the vastus lateralis muscle were observed during both trotting and galloping (Fig. 4). Recordings from two of the dogs showed that the muscle underwent very little shortening during the initial portion of knee extension and then shortened rapidly at a relatively constant rate during the latter portion of knee extension (Fig. 4A,C). In the other two dogs, the muscle shortened continuously at an approximately constant velocity throughout knee extension (Fig. 4B,D). Overall, the rate of shortening was often relatively constant during knee extension, as is illustrated in Fig. 4B,D, and by the last third of limb support in Fig. 4C.

Changes in the length of the vastus lateralis muscle during active shortening were large (Table 3). At relatively high trotting speeds, the mean active shortening ranged from 8.7 to 20.1% of the resting length (i.e. length during standing) of the muscle. During galloping at intermediate speeds (i.e. the fastest speeds at which the dogs would run on the treadmill), active shortening was somewhat greater than during the trot, ranging from 8.8 to 22.1% of resting length. The mean velocity of shortening of the vastus lateralis muscle was also relatively high (Table 3). During trotting, the mean shortening velocities ranged from 1.26 to $2.62 \text{ muscle lengths s}^{-1}$, and during galloping shortening velocity ranged from 1.57 to $3.99 \text{ muscle lengths s}^{-1}$.

Discussion

Gear ratios change during the stance period

The gear ratios of the limb joints of dogs change dramatically during the support period of a running step.

Generally, physiologists have assumed that the gear ratios of the extensor muscles remain roughly constant during the support phase. This is true for the wrist joint until mid-support in trotting dogs. However, for the other joints during trotting, and for all six limb joints during galloping, the gear ratios undergo large changes. This pattern is probably the result of

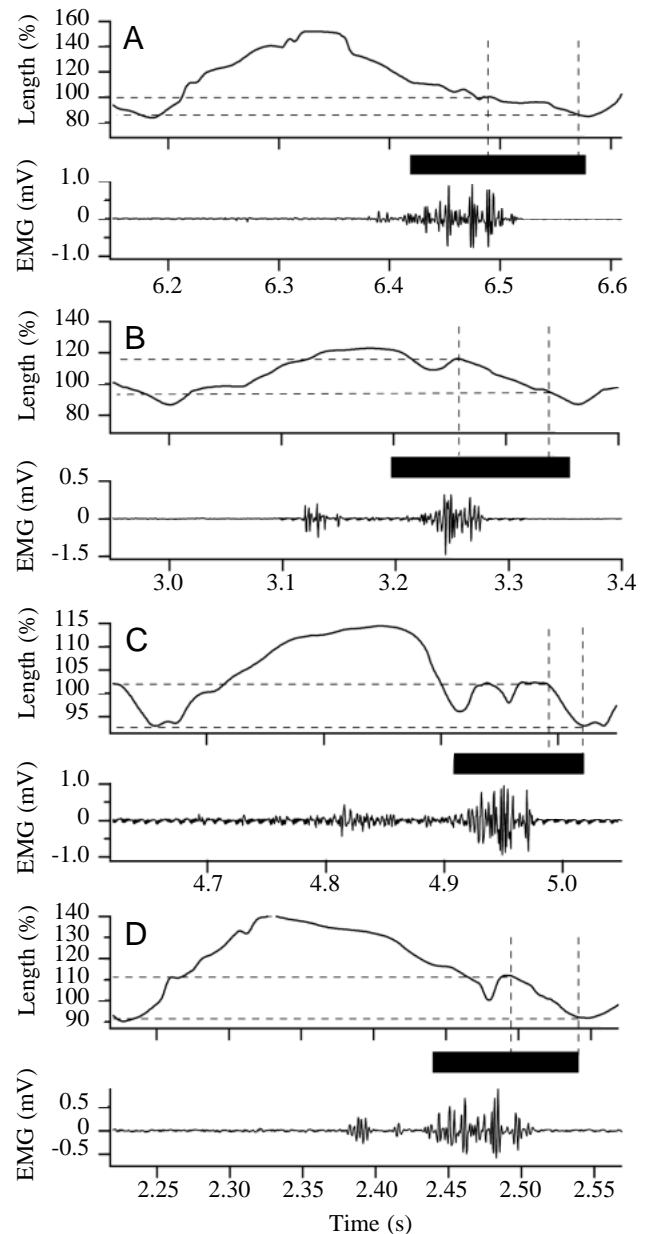

Fig. 4. Sample sonomicrometry and electromyography (EMG) recordings from the vastus lateralis muscle for a single stride from two dogs during trotting (A,B) and galloping (C,D). In each case, the upper graph plots the changes in length of the muscle as a percentage of the resting length (length during standing) of the muscle. The lower graph plots the EMG activity. The filled bar denotes the duration of limb support. The vertical dashed lines indicate the period during which changes in muscle length and muscle velocity were measured (see Materials and methods). A and C are examples from dog F (Table 3). B and D are examples from dog D.

Table 3. Active shortening and velocity of shortening of the vastus lateralis muscle

	Dog D	Dog E	Dog F	Dog G
Length change (%)				
Trot	17.09±1.08	20.07±1.40	8.71±1.45	–
Gallop	20.41±0.83	22.10±3.67	8.82±0.86	9.67±1.80
Shortening velocity (muscle lengths s ⁻¹)				
Trot	2.03±0.24	2.62±0.21	1.26±0.25	–
Gallop	3.72±0.30	3.99±0.69	2.82±0.35	1.57±0.24

Values are means ± s.d. (N=10).
Length change values are expressed as a percentage of the length of the muscle during standing (resting length).

the fact that limbs consist of a series of linked segments which undergo flexion, extension and translation to produce work. As joints flex and extend, their position relative to the ground reaction force vector changes, producing changes in the length of the ground reaction force moment arm. These changes must influence the forces and rates of length change required from muscle-tendon actuators. For example, during constant-speed galloping, the amplitude of the ground reaction force is approximately the same at 30 and 70 % of the support period. Nevertheless, the reduction in gear ratio that occurs at the ankle joint dictates that, for the foot to apply the same force to the ground, the ankle extensor muscles must generate 1.8 times more force at 30 % of the support period than is required at 70 % of support. Similarly, for the ankle to impart the same velocity to the center of mass of galloping dogs, the ankle extensor muscles and tendons would have to shorten twice as rapidly at 80 % of stance than was required at 60 % of stance. Thus, changes in the gear ratio during limb support do influence the function of active muscles during locomotion and may place real limits on the design and performance of limbs.

There are two general patterns of change in gear ratio that warrant consideration. The gear ratio of the wrist, elbow, ankle and hip joints all decrease during support. This type of change in gearing could not enhance the power and efficiency of muscle contraction. If the extensor muscles of the wrist, elbow, ankle and hip joints were to generate work by actively shortening, the observed 'down-shifting' to lower gear ratios would require these muscles to shorten at increasingly higher rates as the velocity of the animal increased. Continuously increasing rates of muscle contraction are not compatible with the maintenance of a muscle at its optimal shortening speed for

efficiency or power generation. Thus, these joints do not exhibit the type of gearing that would maximize the efficiency or power of muscle shortening. However, the pattern of down-shifting observed at the wrist, elbow and ankle is compatible with the effective storage and recovery of elastic strain energy (Gregersen *et al.* 1998). The extensor muscles of the wrist, elbow and ankle joints of dogs do appear to be capable of effective storage and recovery of elastic strain energy during running, but this does not appear to be true of the extensor muscles of the hip joint.

Only the shoulder and knee joints exhibit changes in gear ratio that are consistent with the hypothesis that dynamic gearing could improve the performance of muscle contraction. At both the shoulder and knee joints, the gear ratios are positive at the time that the joints begin to extend, and the ratios increase in a roughly linear manner throughout the remainder of stance. Thus, as a dog accelerates forward during the second half of stance, the gear ratios of these two joints increase in a manner that could maintain the extensor muscles at a roughly constant rate of shortening.

Does the vastus lateralis muscle shorten at a rate that improves its performance?

Our recordings of shortening in the vastus lateralis muscle showed that the muscle shortened at a roughly constant rate in the four dogs studied. Two of the dogs exhibited shortening throughout knee extension, and the other two dogs displayed shortening only during the latter 50–60 % of knee extension. But, in both cases, the muscles shortened at roughly constant velocities. In the two dogs that showed shortening throughout knee extension (dogs D and E in Table 3), the vastus lateralis

Table 4. Allometric relationships for V_{max} versus body mass in mammals and the value that these relationships yield for fast-twitch muscle (type IIB) of a 20 kg mammal at 35 °C

Power equation	Temperature (°C)	V_{max} for 20 kg (fiber lengths s ⁻¹)	Reference
$V_{max}=15.38M_B^{-0.145}$	35	9.96	Close (1972)
$V_{max}=5.01M_B^{-0.073}$	15	12.47*	Rome <i>et al.</i> (1990)
$V_{max}=1.49M_B^{-0.126}$	5	5.57*	Soew and Ford (1991)

*Corrected to 35 °C, assuming a Q_{10} of 1.76 (Ranatunga, 1982).

V_{max} , maximum shortening velocity; M_B , body mass.

muscle had a mean shortening velocity of 3.7–4.0 fiber lengths s^{-1} during galloping. In these dogs, shortening was preceded by active stretching, which has been shown to increase the work done once the muscle begins to shorten (Cavagna *et al.* 1968, 1994). In the other two dogs, the fact that very little shortening occurred during the first half of knee extension suggests that part of the work at the knee was done by elastic storage. However, the active shortening that followed was at a constant velocity. One might expect that the shortening velocity of an extensor muscle would increase as the animal's ground speed increases during a step. The observation that shortening velocity remained constant during knee extension can be explained by the simultaneous increase in gear ratio at the knee.

How do the observed shortening velocities compare with velocities that could be expected to maximize muscle efficiency? To our knowledge, there are no measurements of the shortening velocities of the limb muscles of dogs. Thus, it is difficult to evaluate whether the dynamic gearing observed at the knee is advantageous for contractile efficiency. However, there have been several attempts to determine the way in which the maximum velocity of shortening of skeletal muscle (V_{max}) changes as body size increases in mammals (Table 4). These allometric relationships can be used to estimate V_{max} for the fast muscle in a 20 kg dog. Then, because peak efficiency generally occurs at shortening velocities that are 30–40% of V_{max} , we can determine whether the velocities we observed in the vastus lateralis muscle are in the range expected for peak efficiency.

The three studies listed in Table 4 have determined the allometric relationship between V_{max} of fast-twitch muscle and body size in mammals. The maximum rate of shortening predicted by these allometric relationships for a 20 kg mammal range from 5.57 to 12.47 fiber lengths s^{-1} . If we assume that the vastus lateralis muscles of our galloping dogs shortened at the rate that produced peak efficiency (mechanical power/metabolic cost), and that peak efficiency occurs at 35% of V_{max} , then our data suggest that V_{max} is somewhere in the range 10.6–11.4 fiber lengths s^{-1} (i.e. 3.7 muscle lengths $s^{-1} \times 0.35^{-1}$ to 4.0 muscle lengths $s^{-1} \times 0.35^{-1}$). This prediction for V_{max} of the vastus lateralis muscle of a 20 kg dog is midway between the estimates of the studies of Close (1972) and Rome *et al.* (1990) (Table 4). Our prediction for V_{max} is, however, well above that derived from the study of Soew and Ford (1991). This discrepancy may be due to the low temperature (5 °C) at which Soew and Ford (1991) made their measurements. Soew and Ford (1991) used 5 °C because skinned muscle fibers survive for longer at low temperatures and they were interested in the allometric relationship between body size and shortening velocity, which is presumably not influenced by temperature. However, 5 °C is a very low temperature for endothermic muscle, and there is some indication that the effect of temperature on shortening velocity increases at temperatures below 20 °C (Ranatunga, 1982). If the Q_{10} for shortening velocity does indeed increase below 20 °C, then the estimate for V_{max} based on the study of Soew and Ford (1991) (Table 4)

would underestimate the actual value. Consequently, the shortening velocities of the vastus lateralis muscle recorded during galloping in the present study of 3.7–4.0 muscle lengths s^{-1} do appear to be very close to the value that would produce peak efficiency of muscle contraction in the fast twitch fibers of a 20 kg mammal.

Could dynamic gearing be important to the economy of locomotion?

For dynamic gearing to be important to the economy of locomotion, there must be a significant amount of work produced by those joints that exhibit it. At first glance, the knee joint appears to contribute relatively little to the work of locomotion. Gregersen *et al.* (1998) found that, in dogs, the external work that occurs at the knee joint is only approximately 21% of the work produced by the hindlimbs and only 14% of the total external work produced by both fore- and hindlimbs during galloping. This suggests that, although dynamic gearing may facilitate improved efficiency of contraction of the extensor muscles of the knee, it is unlikely to have a significant effect on the economy of running in dogs.

One factor that could increase the importance of the dynamic gearing at the knee joint is a transfer of energy between the knee and ankle joints (Bobbert *et al.* 1986a,b; van Ingen-Schenau *et al.* 1990; Prilutsky and Zatsiorsky, 1994; Prilutsky *et al.* 1996). Both the gastrocnemius and plantaris muscles cross both the knee and ankle joints. They originate on the caudal side of the distal end of the femur, and in dogs these muscles have a moment arm at the knee joint that is approximately 72% as long as their moment arm around the ankle joint (Gregersen *et al.* 1998). Consequently, extension of the knee puts tension in these muscles and acts to extend the ankle. (It is easy to observe this linkage in any relaxed dog.) Thus, there are two mechanisms for extension of the ankle: (1) shortening of the ankle muscle–tendon systems (i.e. the gastrocnemius and plantaris muscles); and (2) extension of the ankle as a result of extension of the knee joint.

The contribution of the extensor muscles of the knee joint to the work of the ankle joint can be estimated from a consideration of the amount of ankle extension that is produced by the knee. Because shortening of the ankle muscle–tendon systems acts in series with the extension of the ankle joint resulting from knee extension, the contributions to ankle extension of these two mechanisms are additive. During galloping, an average of 56° of extension at the ankle occurs simultaneously with 38° of extension at the knee (Fig. 3). Observations from dissected limbs and manipulations of intact limbs indicate that there is a 1:0.72 relationship between the angular extension at the knee and the resulting extension of the ankle joint (Gregersen *et al.* 1998). This relationship indicates that 27° (72% of 38°) of the 56° of extension that occurs at the ankle is due to knee extension. Thus, 49% of the observed ankle extension is produced by shortening of the quadriceps muscles rather than by shortening of the ankle extensor muscles. If we assume that the extension of the ankle that is due to extension of the knee occurs simultaneously with the

ankle extension that results from shortening of the ankle extensor muscles, then approximately 49% of the positive external work done at the ankle during galloping is a result of shortening of the knee extensor muscles and, surprisingly, only 51% of the ankle work is produced by the ankle extensor muscles.

This analysis of the linkage between ankle and knee extension leads to the suggestion that the dynamic gearing observed at the knee joint makes a significant contribution to the economy of running in dogs. If 49% of the work done at the ankle joint is actually produced by the extensor muscles of the knee, then the total contribution of the knee extensor muscles to the external work produced by the hindlimb is approximately 41% rather than the 21% discussed above, and 27% of the total external work produced by the six joints analyzed is actually produced by the extensor muscles of the knee (Gregersen *et al.* 1998). Thus, the dynamic gearing observed at the knee joint of dogs may make a significant contribution to the economy of running.

Implications for limb design

If dynamic gearing is beneficial, why are there only two joints in running dogs in which it appears to occur? We suspect there are two reasons. First, it may be difficult or impossible for the gear ratio to increase at more than one joint as a limb extends. Because the joints of a limb are linked by skeletal elements, as one joint is drawn away from the ground reaction force vector, increasing its gear ratio, the adjacent joint above or below it will be drawn closer to the reaction vector and will undergo a decrease in gear ratio. This appears to be the case in the hindlimb of running dogs and humans (Carrier *et al.* 1994).

A second possible reason why dynamic gearing was observed at only two joints in our dogs may be the multiple demands placed on the limbs of dogs. If the locomotion of dogs consisted entirely of running at steady speed on level surfaces, it might be advantageous to have all the muscle-tendon systems of the limbs functioning as energy-storing springs. In this case, dynamic gearing would not be beneficial (Gregersen *et al.* 1998). However, in addition to running on level surfaces, dogs must be able to run up and down hill and accelerate quickly. Running up hill (Roberts *et al.* 1997) and rapid accelerations (Cavagna *et al.* 1971) require muscles that actively shorten to produce work. Shortening muscles in series with elastic elements could be expected to expend energy in stretching the elastic elements, thereby dissipating the displacement applied to the center of mass and reducing the acceleration of the animal. Consequently, one might expect the limbs of dogs to be a composite of muscle-tendon systems that have a pronounced capacity for elastic storage and other muscle-tendon systems that are designed to produce work by active shortening. Several studies have found that it is the distal muscles of limbs that are best suited for elastic storage (Alexander, 1984; Gregersen *et al.* 1998). If this is the case, then there may be a division of labor within limbs, with the more proximal muscles functioning to produce accelerations

by actively shortening. The performance of dogs would be enhanced if the muscles that produce work by active shortening operated with dynamic gearing.

Although only the shoulder and knee joints displayed the characteristics of dynamic gearing, the benefits of this gearing may be distributed to other joints in the limb. Both the shoulder and knee have two-joint muscles with potential to transfer energy to more distal joints during limb extension. The long head of the triceps muscle may transfer energy from the extensor muscles of the shoulder to the elbow joint, and the gastrocnemius and plantaris muscles have been shown to transfer energy from the knee to the ankle (Bobbert *et al.* 1986a,b; Prilutsky and Zatsiorsky, 1994; Prilutsky *et al.* 1996). Thus, the work done by the proximal muscles and their capacity to produce work by the transfer of energy to more distal segments may be facilitated by dynamic gearing.

In summary, the changes in gearing observed at the elbow, wrist, hip and ankle joints in trotting and galloping dogs are not compatible with the hypothesis of dynamic gearing. In contrast, at the shoulder and knee joints, the gear ratio increases during joint extension in manner that may facilitate efficient shortening of the extensor muscles. Recordings of the shortening velocity of the vastus lateralis muscle show that it shortens at a constant velocity when dogs gallop at intermediate speeds. Furthermore, the rate of shortening in this muscle is within the range of speeds that produce peak efficiency in fast-twitch muscle in mammals of this body size. Finally, analysis of the external work of locomotion indicates that the extensor muscles of the knee produce a relatively large amount of work. These observations suggest that dynamic gearing at the knee and shoulder joints may contribute to the economy of locomotion of running dogs. Although other mechanisms, such as elastic storage, are likely to be much more important in reducing the cost of steady-speed locomotion, dynamic gearing may play an important role in the integrated function of terrestrial limbs.

We thank A. A. Biewener, D. M. Bramble, M. H. Dickinson, C. T. Farley, R. J. Full, N. C. Heglund, R. L. Marsh, R. Kram and T. J. Roberts for conversations that were critical to the development of the project. R. L. Marsh provided tutoring in the use of sonomicrometry. C. Bailey, J. Demetropoulos and D. Stettler helped to train and run the dogs. D. M. Bramble and F. A. Jenkins provided the cineradiographic recordings from which we determined the change in angle of the shoulder joint during running. Two anonymous reviewers provided helpful comments on the manuscript. This investigation was supported by The National Science Foundation: IBN 9258243 and IBN 9306466.

References

- ALEXANDER, R. MCN. (1983). *Animal Mechanics*. Edinburgh: Blackwell Scientific Publications. pp. 34–36.
 ALEXANDER, R. MCN. (1984). Elastic energy stores in running vertebrates. *Am. Zool.* **24**, 85–94.

- ALEXANDER, R. MCN. (1988). *Elastic Mechanisms in Animal Movement*. Cambridge: Cambridge University Press. pp. 30–50.
- ALEXANDER, R. MCN., JAYES, A. S., MALOIJ, G. M. O. AND WATHUTA, E. M. (1981). Allometry of the leg muscles of mammals. *J. Zool., Lond.* **194**, 539–552.
- BETTS, B., SMITH, J. L., EDGERTON, V. R. AND COLLATOS, T. C. (1976). Telemetered EMG of fast and slow muscles of the cat. *Brain Res.* **117**, 529–533.
- BIEWENER, A. A. (1982). Bone strength in small mammals and bipedal birds: do safety factors change with body size? *J. exp. Biol.* **98**, 289–301.
- BIEWENER, A. A. (1983). Allometry of quadrupedal locomotion: the scaling of duty factor, bone curvature and limb orientation to body size. *J. exp. Biol.* **105**, 147–171.
- BIEWENER, A. A. (1989). Scaling body support in mammals: limb posture and muscle mechanics. *Science* **245**, 45–48.
- BIEWENER, A. A. AND FULL, R. J. (1992). Force platform and kinematic analysis. In *Biomechanics, Structures and Systems: A Practical Approach* (ed. A. A. Biewener), pp. 45–73. Oxford: Oxford University Press.
- BOBBERT, M. F., HUIJING, P. A. AND VAN INGEN SCHENAU, G. J. (1986a). A model of the human triceps surae muscle–tendon complex applied to jumping. *J. Biomech.* **19**, 887–898.
- BOBBERT, M. F., HUIJING, P. A. AND VAN INGEN SCHENAU, G. J. (1986b). An estimation of power output and work done by the human triceps surae muscle–tendon complex in jumping. *J. Biomech.* **19**, 899–906.
- CARRIER, D. R. (1996a). Ontogenetic limits on locomotor performance. *Physiol. Zool.* **69**, 467–488.
- CARRIER, D. R. (1996b). Function of the intercostal muscles in trotting dogs: ventilation or locomotion? *J. exp. Biol.* **199**, 1455–1465.
- CARRIER, D. R., HEGLUND, N. C. AND EARLS, K. D. (1994). Variable gearing during locomotion in the human musculoskeletal system. *Science* **265**, 651–653.
- CAVAGNA, G. A., DUSMAN, B. AND MARGARIA, R. (1968). Positive work done by a previously stretched muscle. *J. appl. Physiol.* **24**, 21–32.
- CAVAGNA, G. A., HEGLUND, N. C., HARRY, J. D. AND MANTOVANI, M. (1994). Storage and release of mechanical energy by contracting frog muscle fibers. *J. Physiol., Lond.* **481**, 689–708.
- CAVAGNA, G. A., HEGLUND, N. C. AND TAYLOR, C. R. (1977). Mechanical work in terrestrial locomotion: two basic mechanisms for minimizing energy expenditure. *Am. J. Physiol.* **233**, R243–R261.
- CAVAGNA, G. A., KOMAREK, L. AND MAZZOLENI, S. (1971). The mechanics of sprint running. *J. Physiol., Lond.* **217**, 709–721.
- CAVAGNA, G. A., SAIBENE, F. P. AND MARGARIA, R. (1964). Mechanical work in running. *J. appl. Physiol.* **19**, 249–256.
- CLOSE, R. I. (1972). Dynamic properties of mammalian skeletal muscles. *Physiol. Rev.* **52**, 129–197.
- FARLEY, C. T., BLICKHAN, R., SAITO, J. AND TAYLOR, C. R. (1991). Hopping frequency in humans: a test of how springs set stride frequency in bouncing gaits. *J. appl. Physiol.* **71**, 2127–2132.
- FARLEY, C. T., GLASHEEN, J. AND MCMAHON, T. A. (1993). Running springs: speed and animal size. *J. exp. Biol.* **185**, 71–86.
- FENN, W. O. AND MARSH, B. S. (1935). Muscular force at different speeds of shortening. *J. Physiol., Lond.* **85**, 277–297.
- GREGERSEN, C. S., SILVERTON, N. A. AND CARRIER, D. R. (1998). External work and potential for elastic storage of energy at the limb joints of running dogs. *J. exp. Biol.* **201**, 3197–3210.
- HILDEBRAND, M. (1995). *Analysis of Vertebrate Structure*, 4th edition. New York: Wiley & Sons. pp. 465–468, 491.
- HILL, A. V. (1938). The heat of shortening and the dynamic constants of muscle. *Proc. R. Soc. B* **126**, 136–195.
- HILL, A. V. (1950). The dimensions of animals and their muscular dynamics. *Sci. Prog.* **38**, 209–230.
- OLSON, J. M. AND MARSH, R. L. (1998). Activation patterns and length changes in hindlimb muscles of the bullfrog (*Rana catesbeiana*) during jumping. *J. exp. Biol.* **201**, 2763–2777.
- PRILUTSKY, B. I., HERZOG, W. AND LEONARD, T. (1996). Transfer of mechanical energy between ankle and knee joints by gastrocnemius and plantaris muscles during cat locomotion. *J. Biomech.* **29**, 391–403.
- PRILUTSKY, B. I. AND ZATSIORSKY, V. M. (1994). Tendon action of two-joint muscles: transfer of mechanical energy between joints during jumping, landing and running. *J. Biomech.* **27**, 25–34.
- RANATUNGA, K. W. (1982). Temperature-dependence of shortening velocity and rate of isometric tension development in rat skeletal muscle. *J. Physiol., Lond.* **329**, 465–483.
- ROBERTS, T. J., MARSH, R. L., WEYAND, P. G. AND TAYLOR, C. R. (1997). Muscular force in running turkeys: the economy of minimizing work. *Science* **275**, 1113–1115.
- ROME, L. C., FUNKE, R. P., ALEXANDER, R. MCN., LUTZ, G., ALDRIDGE, H., SCOTT, F. AND FREADMAN, M. (1988). Why animals have different muscle fiber types. *Nature* **335**, 824–827.
- ROME, L. C., SOSNICKI, A. A. AND GLOBE, D. O. (1990). Maximum velocity of shortening of three fibre types from horse soleus muscle: implications for scaling with body size. *J. Physiol., Lond.* **431**, 173–185.
- SEOW, C. Y. AND FORD, L. E. (1991). Shortening velocity and power output of skinned muscle fibers from mammals having a 25,000-fold range of body mass. *J. gen. Physiol.* **97**, 541–560.
- VAN INGEN-SCHENAU, G. J., BOBBERT, M. F. AND VAN SOEST, A. J. (1990). The unique action of bi-articular muscles in leg extensions. In *Multiple Muscle Systems, Biomechanics and Movement Organization* (ed. J. M. Winters and S. L. Y. Woo), pp. 639–652. New York: Springer.