

Foraging in a complex naturalistic environment: capacity of spatial working memory in flower bats

York Winter^{1,2,*} and Kai Petra Stich²

¹Department of Biology, University of Munich, 82152 München-Martinsried, Germany and ²Max-Planck Institute for Ornithology, 82319 Seewiesen, Germany

*Author for correspondence (e-mail: winter@zi.biologie.uni-muenchen.de)

Accepted 30 November 2004

Summary

Memory systems have evolved under selection pressures, such as the need to remember the locations of resources or past events within spatiotemporally dynamic natural environments. The full repertoire of complex behaviours exhibited by animals in dynamic surroundings are, however, difficult to elicit within simply structured laboratory environments. We have developed a computer-controlled naturalistic environment with 64 feeders for simulating dynamic patterns of water or food resource availability (depletion and replenishment) within the laboratory. The combination of feeder and cage remote control permits the automated transfer of animals between cage and test arena and, therefore, high experimental throughput and minimal disturbance to the animals (bats and mice). In the present study, we investigated spatial working memory in nectar-feeding bats (*Glossophaga soricina*, Phyllostomidae) collecting food from a 64-feeder array. Feeders gave only single

rewards within trials so that efficient foraging required bats to avoid depleted locations. Initially, bats tended to revisit feeders (win-stay), but within three trials changed towards a win-shift strategy. The significant avoidance of revisits could not be explained by algorithmic search guiding movement through the array nor by scent cues left by the bats themselves and, thus, the data suggest that bats remembered spatial locations depleted of food. An examination of the recency effect on spatial working memory after bats shifted to a win-shift strategy indicated that bats held more than 40 behaviour actions (feeder visits) in working memory without indication of decay. This result surpasses previous findings for other taxa.

Supplementary material available online at
<http://jeb.biologists.org/cgi/content/full/208/3/539/DC1>

Key words: spatial memory, orientation, cognition, foraging, bats.

Introduction

Many animals are able to relocate places they have previously visited. This ability requires what is collectively referred to as 'spatial memory', although the underlying mechanisms for orientation and place-finding can be rather diverse (Redish, 1999; Jeffery, 2003). Rats build representations of many spatial locations from familiar environments in long-term memory. Together with findings from other species this led to the assumption that at least mammals and birds may generally be able to learn a topological representation of their environment (i.e., spatial neighbourhood relationships) including metric information (distances and directions) but with varying precision (Redish, 1999; Eichenbaum and Cohen, 2001; Trullier et al., 1997; Shettleworth, 1998). This mental representation of the spatial environment is accessed by mechanisms that can include cognitive functions. It is used for route planning, but probably not at the abstract level of human map reading (Janson, 1998; Gallistel and Cramer, 1996; Wang and Spelke, 2002).

Within the natural environment, typical mammal or bird foraging excursions will normally consist of multiple locations

to be visited in sequence rather than just being directed towards a single goal. To prepare such sequences, cognitive mechanisms may enable animals to identify spatial locations of interest and chain them into a visitation sequence. Beyond coding spatial coordinates there must therefore be an association of the places with the resources they offer and thus of an individual's past experience with those places. This information must exist over several temporal scales, since an animal must be able to distinguish places both by their general, long-term utility (i.e. food productivity) and by their short-term utility (i.e. their visitation history). Accordingly, rats remember their feeding activity at specific places in spatial working memory, which allows them to avoid productive sites after having emptied them of food (Roberts, 1984).

Simple but otherwise successful behaviour paradigms for spatial memory ability (water maze, radial arm maze) do not suffice to investigate strategies of exploiting naturalistically complex, temporally dynamic spaces. Most importantly, laboratory environments with only a few potential goals and the inability to change attributes dynamically may not be

adequate to challenge complex behaviours that possibly involve behavioural planning. In addition, the efficient behavioural testing of animals in dynamic and complex environments under minimal disturbance is hardly possible without automated methods for objective behavioural data recording (e.g. Gass, 1977, 1978; Young et al., 1993; Mauck and Dehnhardt, 1997; Tsibulsky and O’Gower, 2002; Fry et al., 2000; Taylor et al., 2002; Kao et al., 1995; Gerhardt et al., 1998; Hagstrum et al., 1996). We developed a novel automated experimental system for the simulation of a complex naturalistic environment with dynamic food availability for sequential behaviour experiments with multiple individuals. In the present study we used it to examine how flower-visiting bats acquire a spatial win-shift task in a 64-feeder environment.

Neotropical flower bats (Glossophaginae, Phyllostomidae) exploit an ecological environment characterised by spatially predictable feeding sites (flowers) with a resource (nectar) of temporally dynamic availability (Winter and von Helversen, 2001). Previous work has shown that once the spatial location of a flower is known, *Glossophaga* primarily uses spatial memory to relocate such food targets (Thiele and Winter, 2004). In addition, the hippocampus of nectar-feeding glossophagine bats is 50–100% larger in size than the carnivorous/insectivorous members of the same family (Phyllostomidae; Baron et al., 1996; U. Kaupert and Y. Winter, unpublished). This may indicate a specialized cognitive adaptation to a trophic niche where the predictability of both spatial location and the dynamics of food resource availability (flower nectar) challenge an animal to optimise foraging trajectories. This raises questions about behavioural competences gained from hippocampal enlargement and of the trade-offs involved. We designed the present study to estimate the capacity of spatial working memory for this mammalian spatial memory specialist. We presented single bats of the species *Glossophaga soricina* with a 64-feeder win-shift foraging task at a vertically oriented array of feeders inspired by the experimental design of Sutherland and Gass (1996). Feeders gave only single rewards so that bats had to remember the spatial distribution of their own previous foraging activity within the current bout of foraging to forage efficiently.

Materials and methods

Experimental testing system

We developed the following method to investigate spatial memory for food sites in nectar feeding bats (Glossophaginae Geoffroy). As this present study is the first for which we have used this experimental system, we describe it in some detail. Both data collection and animal translocation are under automatic computer control. The system is disturbance free for up to six animals per day and allows a high throughput of behavioural recording. It consists of two independent units: (1) an array with 64 liquid feeders (i.e. water or sugar water); and (2) six computer-controlled individual cages. The feeder array constitutes a foraging environment with both spatially and temporally variable conditions of food availability. The state

of feeders (rewarding or non-rewarding, presence of perceptible cues) can be programmed individually and may be dynamically dependent on the subject’s exploitation behaviour. Visual, echo acoustic, or olfactory stimuli can be presented automatically at feeders (but were not used for the experiments described below). This simulated naturalistic foraging environment in the laboratory allows the investigation of foraging behaviour and spatial memory for food location under variable and dynamic conditions of food availability and presence of sensory cues.

Individual cages are equipped with feeders, a remote surveillance system and computer-controlled doors. This allows for the automatic release of an animal from its cage to the room containing the experimental feeder array and its subsequent return to its cage, followed by resetting the array and release of the next animal. With this system animals can alternately search for food independently in the same array for given time intervals without the presence of test personnel.

Cage and feeder system

Feeders can be adjusted to supply variable amounts of a liquid (e.g. water or sugar water). For detection and timing of visits each feeder (Fig. 1) has an infrared diode and light sensor at its front edge. For our experiments with hover-feeding bats, this sensor determines the time and duration of a feeding event with 1 ms resolution. An outer ring of PVC masks the wiring and provides a uniform outer appearance, both visually and echo acoustically. The supply of sugar water is controlled by a pinch valve at each feeder and a single electronic pump for the feeder system that holds the sugar water in a gas-tight injector. Food is delivered only after arrival, so that an animal cannot sense its presence beforehand.

Feeders can present three different types of stimuli. A green LED can serve as a visual stimulus. An odour current controlled by a pinch valve can be issued from a 1 mm hole as an olfactory stimulus. A motorised swivel arm can present shapes offering visual or echo-reflecting stimuli. For the experiment reported here, no stimuli were activated and all feeders were of the same external appearance and were programmed identically.

Individual cages each contain two feeders, a resting place connected to an electronic balance that detects presence and monitors body weight, an infrared (IR) sensitive video camera for observation and motion detection, and an IR lamp (860 nm) for illumination. Animals cannot see the feeder array from the cage with sidewalls that are opaque PVC, but external light can enter through the roof and back wall that are transparent Perspex. Cages are accessible through a Perspex door (Fig. 2) and have an additional motor-operated guillotine door that serves as an entry hatch.

The perch hangs from an electronic balance (Scout SR2020; VWR-Merck Biosciences, Ismaning, Germany) connected to a PC, which registers the presence and weight of the bat to 10 mg resolution. A small roof over the perch provides shade from daylight. Individual cameras can be selectively connected to a

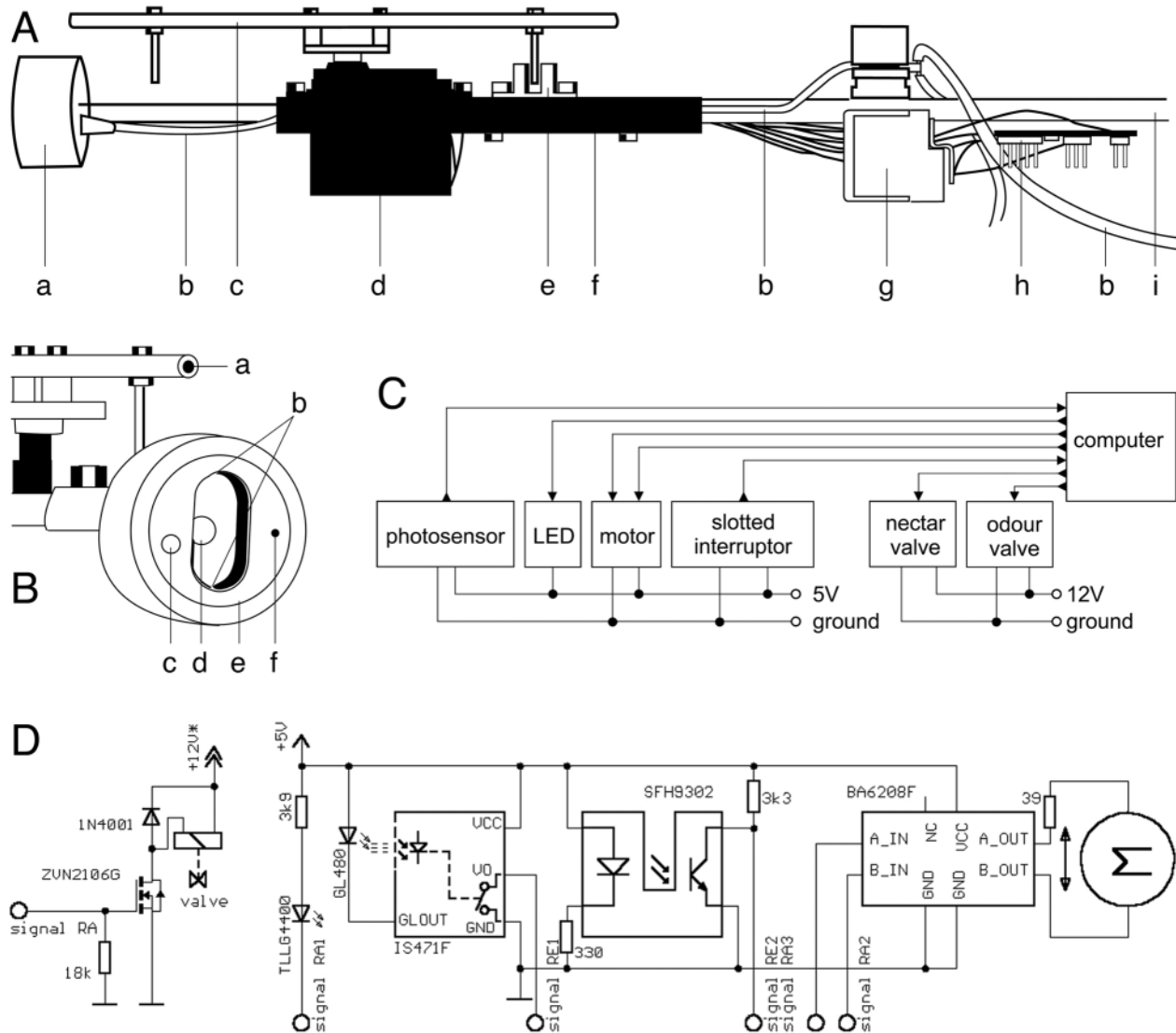

Fig. 1. Experimental feeder. (A) side view, (B) frontal view, (C) block diagram of feeder components (arrows indicate signal direction) and (D) diagram of electronic circuit. Details in (A) are: a, feeder head; b, tube for food solution; c, swivel arm; d, motor; e, slotted interrupter; f, plastic cover for cables and tube; g, valve; h, connector; i, aluminium carrier. For experimental animals only the front part of the feeder to the end of the plastic cover is perceivable (left part of drawing). Details in (B) are: a, swivel arm; b, infra-red photo trigger; c, LED; d, food port; e, PVC head; f, odour port. Development partly in cooperation with Animal Cognition Systems. For further details see supplementary material.

motion alarm *via* a camera switch for detection of movement in the cage.

The electric door and the supervision system make it possible automatically to lock an animal in or out. When an animal has completed a trial, the cage door is opened and the motion sensor of the video camera activated. When an activity signal is received from within the cage (feeder, balance, or motion alarm), the door is closed. When a further activity signal is received from within the cage after the door has been closed, the enclosing process is completed and the door of the next cage will be opened. While doors close slowly to prevent injury, these agile fliers may still escape through the moving door. A mechanical flight barrier erected within the cage prevents such escapes.

Sixty-four identical feeders (self-built) are mounted in an array of eight by eight with a distance of 25 cm between feeders (horizontal and vertical) on an aluminium stand with a PVC blind to shield backside cables and tubing. The frame is tilted 15° forward to prevent liquid from dropping onto feeders below during cleaning. The vertical arrangement of feeders leads to a hydrostatic pressure difference between horizontal rows of feeders. We compensate for this through pressure adjustment, which is essential for achieving identical feed volume at all 64 feeders. Pressure regulation is achieved in two steps. During operation, the tubing system is under slight positive pressure. The pressure in the tube system is adjusted to normal for the specific height of the visited feeder before a reward is given. This occurs through the brief opening of an

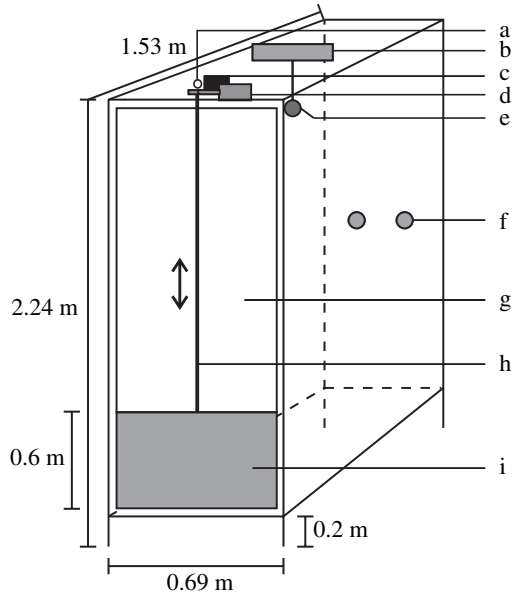

Fig. 2. Experimental cage. Details: a, white light LED; b, electronic balance for roost; c, surveillance video camera; d, cage door motor; e, hanging roost; f, feeder; g, door; h, rope for guillotine door; i, computer-controlled guillotine door (lower quarter made of elastic rubber to prevent injury). Side walls are opaque PVC and front, back and top walls are transparent.

overflow valve at the same height as the visited feeder. This delays liquid delivery by 180 ms. During the subsequent opening of a feeder valve no elastic or hydrostatic pressure is on the system and only the food pump causes liquid flow. After delivery of each unit of liquid, the pump again sets the whole tubing system under slight positive pressure. Calibrations confirmed that by this measure all feeders gave identical reward volumes without measurable systematic error.

The computer controls the 650 TTL-data links connected *via* four I/O-interfaces with 192 TTL I/O-lines each and the serial data lines from the balance that are connected to an 8-port RS-232 card (Fig. 3). DC electricity is supplied from outside the experimental room to exclude transformer noise and also the zero noise computer without fans provides no acoustical landmark.

Operation

Automated tests can be conducted on six animals simultaneously, with individuals being active in the test arena alternately. Animals can be released to the feeder array in any order. Feeders at the array can be programmed to be active at the same time or in succession, and a feeder's condition can be signalled by stimuli of the different sensory modalities. The spatial distribution of rewarding and non-rewarding

feeders is freely adjustable and can be different for particular individuals. Trial duration may depend on a fixed time interval or on the number of feeder visits and can be adapted individually. Practical operation is illustrated in Fig. 4. After acclimatisation in the cages to get used to feeders, stimuli and the environment, one animal at a time is released for an experimental trial to the feeder array. For experiments with *Glossophaga soricina* we found it optimal to have only three animals flying alternately so that each can have 20 trials at the feeder array in one night's work (Fig. 4). At the beginning of the night the animals have half an hour to drink nectar from the cage feeders (nectar-feeding bats respond better after initial feeding and rehydration before trials are started). The computer activates the feeder array and deactivates rewards in the first cage. The trapdoor is then opened electronically and the animal leaves the cage. The cage door is closed behind the animal after its first visit to a feeder in the array, and the animal can visit feeders in any sequence for the duration of the trial. After this time the computer reopens the cage door, which by its noise signals the end of a trial, switches off the feeder array and switches on the cage feeders. After re-entry into the cage and electronic detection (balance, video motion alarm, or visit to a feeder) the door is closed. When the animal is locked in, the next door is opened and the next bat can visit the feeder array.

Subjects and experimental procedure

In the present study we used the 64-feeder system to estimate the capacity of spatial working memory in a nectar-feeding bat, by presenting single bats with a win-shift foraging

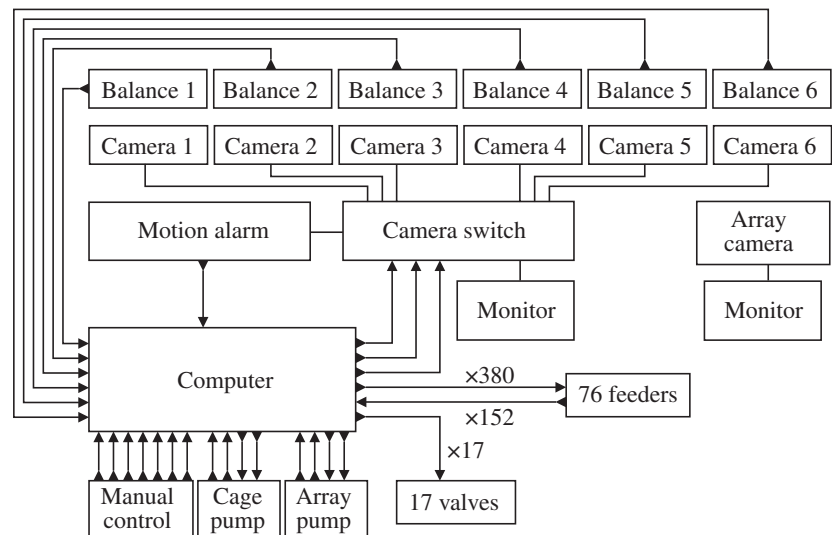

Fig. 3. Data lines between 64-feeder array, six experimental cages and computer. Arrows show direction of data transfer. IO-cards are Decision Computer model 48-192 I/O ISA based on IC 8255. Camera switch is PIH 200-8, CS Lilin (Sintron) and motion alarm is PIH 6004, CS Lilin (Sintron), modified for computer operation. Pumps are custom stepper motor pumps, which move a pallet along a screw spindle that, in turn, moves the piston of a gas tight injector (Hamilton, 1025TTL, 25 ml). In forward drive it delivers nectar and in reverse drive the pump can empty the tube system for automatic cleaning operation. For further details see supplementary material.

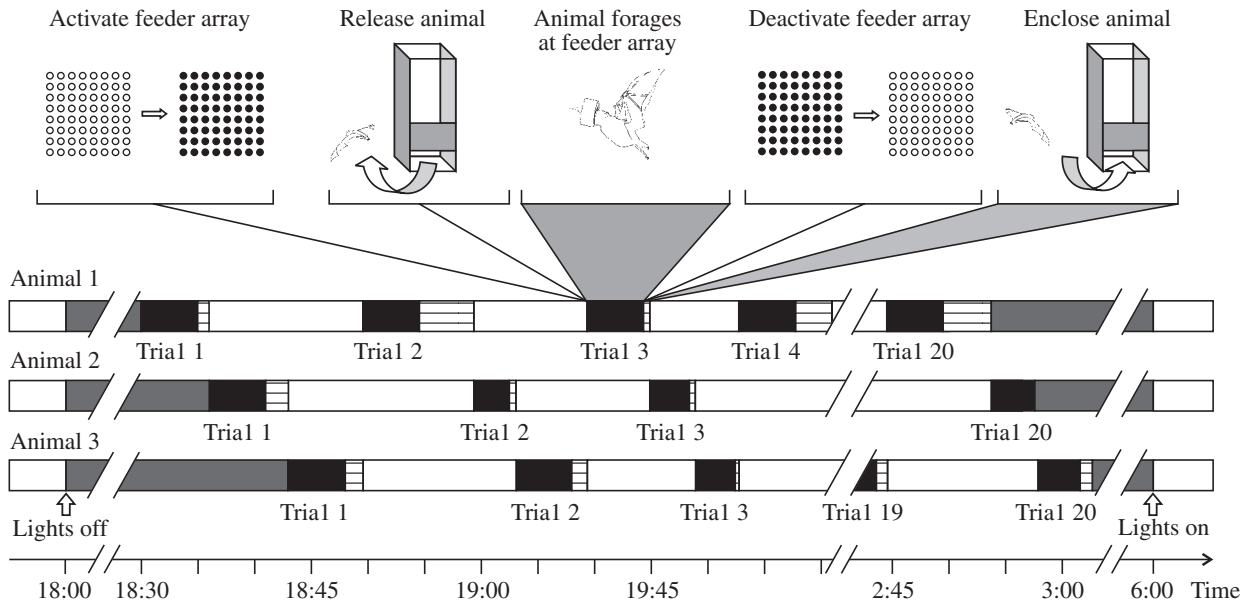

Fig. 4. Interleaved timing of 60 automatically administered trials during one experimental night with three animals sequentially exchanged between the 64-feeder array (trial) and their individual cages (inter-trial). Shading indicates trial at the feeder array (black), enclosure phase (horizontal stripes), animal in cage before and after a series of experimental trials (dark grey). Feeders at array are active (black circles) or inactive (open circles) but indistinguishable in external appearance (not cued) for the test animal.

task at the vertically oriented array of feeders. Experimental subjects were 17 adult male *Glossophaga soricina* Pallas (Phyllostomidae, Glossophaginae) bred in captivity. One individual with few visits during some trials was excluded from some of the analyses. After transfer from the animal facility, bats could accustom themselves to their individual cages and feeders for 1 day. This was the only pre-training of the animals before data collection began. Thus each bat was experimentally naïve on first confrontation with the feeder array. Starting on day 2, they were released individually to feed at the array, where each feeder gave a single reward on the first visit (10 μ l of 17% wt/wt; Bolten et al., 1979, containing sucrose, fructose and glucose in equal parts as typical for nectar from bat pollinated flowers; Baker and Baker, 1990). Bats spontaneously probed feeders on their first visit to the array and readily alternated between cage and feeder array. Each trial lasted until 64 visits to feeders had been made or 5 min had passed since the first visit to a feeder, whichever came first. Bats were free to revisit feeders at will, but for efficient feeding, they had to learn to visit feeders only once (win-shift behaviour). In general, bats trained quickly to this protocol and we had few problems running three animals per night.

Results

Spatial preferences

The spatial distribution of foraging effort at the 64-feeder array followed a number of regularities. In general, bats developed a preference for feeders in the corners of the array (especially the bottom corners in early trials), followed by those along the sides and visited central feeders least often.

These preferences led to the spatial distribution of feeder visits shown in Fig. 5.

Movement within array

Bats made on average 37.3 feeder visits (± 2.3 s.d., range 15–64) during 5 min trials (after trial 10) and emptied 28.6 (± 1.5 s.d.) of the feeders. Bats often visited feeders in an uninterrupted sequence of visits at the array. They also often briefly circled through the room between visits, especially after they had received a reward. Generally, the next feeder was usually not adjacent to the previous one (Fig. 6A). On average, the next feeder visited after a reward was 4.6 feeder positions away ($= 4.6 \times 25$ cm). After an unrewarding visit, the distribution was bimodal with peaks at distances of two and five feeders from the previous one (Fig. 6A). Thus, bats did not move through the array by applying the simple search rule of systematically visiting adjacent feeders but instead tended to jump between non-adjacent positions that were more than half the width of the array apart. This is an important result.

The direction of movement between successively visited feeders was significantly non-random. Of the eight rows of feeders available for each visit (12.5% random chance of selecting a specific row), bats tended to stay within the same row visited previously. After an unrewarding visit, bats next chose the same row in 41% of choices (s.d. 12%, $N=16$), more often than expected if they had selected rows by chance ($t=9.9$, d.f.=15, $P<0.001$). After a reward, the frequency was 29% (s.d. 5.7%, $N=16$), also significantly more often than expected by chance ($t=11.9$, d.f.=15, $P<0.001$). In addition, bats were less likely to remain within the same row after receiving a reward than after not receiving a reward from a visit (paired- $t=4.86$,

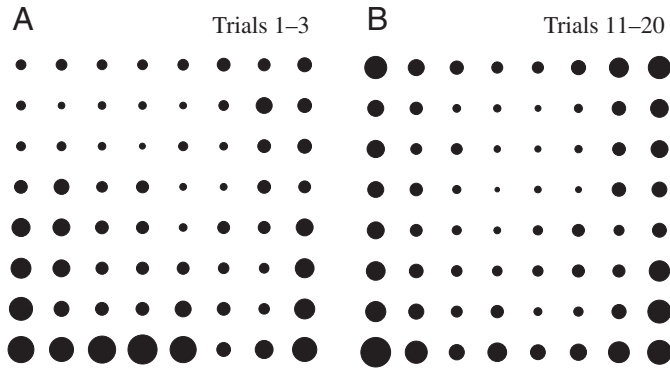

Fig. 5. Spatial distribution of first visits to feeders (i.e. excluding revisits during trials) at the 64-feeder array during trials 1–3 (A) and trials 11–20 (B) by all 17 individuals in all n trials. Circle diameters are proportional to the percentage of first visits directed at that feeder (same scale for A and B). Amounts of single food rewards were equal at all feeders (see Materials and methods). The shortest path between cage exits and feeder array was to the bottom left corner of the array (about 3–4 m from the different cages).

d.f.=15, $P<0.001$). Bats avoided moving vertically up or down (only 5% of choices) but rather moved diagonally in changing horizontal rows. The proportion for a single feeder to be the next visited was 4.5% for each of the seven feeders in the same row, 0.8% for each feeder in the same column, and 1.5% for each of the 49 feeders from a different row and column. Taken together, bats had clear biases in moving through the array but did not seem to apply a simple or stereotypic search rule.

Temporal sequence of visits

The temporal sequence of visits was characterised by median time intervals between successive visits of 1.2 s ($N=1009$) after non-rewarded, and 2.5 s ($N=3501$) after rewarded visits (Fig. 6B). Thus, visits within sequences followed in quick succession, especially when no reward was obtained. The bimodality in interval durations reflects the bats' tendency to circle the room after receiving a reward rather than visiting the next feeder directly. Feeder visits lasted between 500 ms (non-rewarded) and 800 ms (rewarded, modal values), reflecting the time needed to ingest the reward.

Win-stay and win-shift

Initially, bats tended to revisit in the same trial feeders from which they had received rewards (win-stay) so that on average 42% of all feeder visits were revisits during the very first trial (or 34% during the first three trials; Fig. 7A). However, bats learnt rapidly that rewards were given only once and adjusted their behaviour. After trial 10, the frequency of revisits was significantly below expectation assuming random choice of feeders. We obtained this result by computing for each visit to a feeder the number of currently empty feeders divided by 64, which gives the chance probability of revisiting. For each individual we calculated the mean of these data over all visits from all trials included. For the same visits we determined the proportion of revisits actually made. To have comparable data,

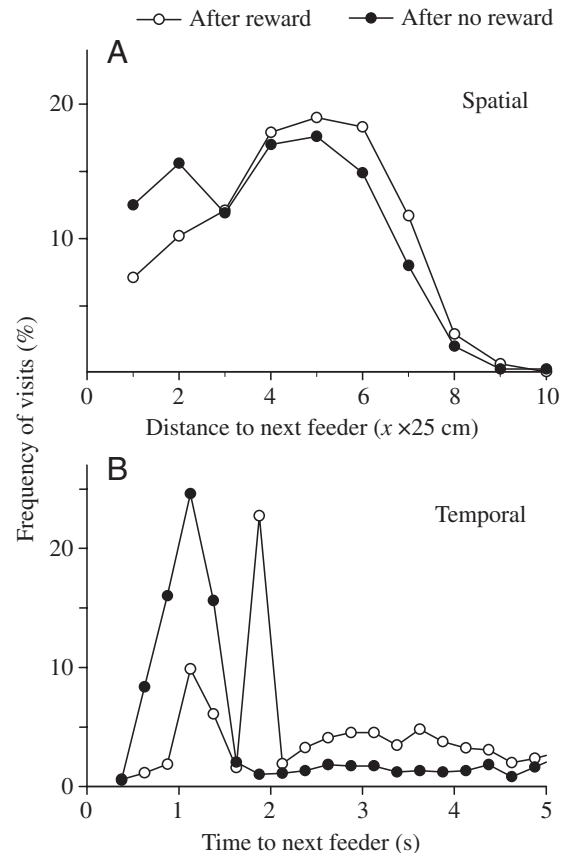

Fig. 6. Spatial (A) and temporal (B) spacing of successive visits to the 64-feeder array. Data based on $N=3465$ (after reward) and $N=1028$ (after no reward). Hovering duration was not included in the calculations of the between-feeder visit intervals in (B).

this analysis was restricted to the first 20 visits of trials. We compared individually expected with individually observed revisits using paired t -tests and the results are shown in Fig. 7A. During trials 1–3, revisits occurred significantly more often than expected by chance (paired t -test, $t=5.4$, d.f.=14, $P<0.001$). There was no significant difference from chance expectation during trials 4–10 (paired t -test, $t=0.5$, d.f.=15, not significant), while during trials 11–20 revisits occurred significantly less often than expected by chance (paired t -test, $t=2.8$, d.f.=15, $P=0.014$).

In the previous analysis we calculated the mean over the entire set of trials. For the following we considered performance within a trial. Within trials, bats revisited feeders significantly less often than expected from chance performance up to the 25th visit during a trial (Fig. 7B). This was determined by using the same data as above. However, instead of averaging over entire trials we averaged for each individual over successive blocks of five visits within trials. This gave us a pair of measured and expected values for each individual for each block of five-visit intervals during a trial. Up to the 25th visit during a trial bat performance exceeded chance level (Wilcoxon test, $Z_s>2.1$, $N_s=16$, $P_s<0.05$).

In addition, it was interesting to note that if individuals were

split equally into high and low performers (an artificial distinction, since distribution of performance between individuals was continuous) then the high group initially revisited feeders during a single trial at 40% the rate expected from chance and remained below 80% of chance level up to the 45th visit during a trial. The low performers, conversely, revisited feeders at a rate of 80% (and above) of chance level from the very beginning of a single trial. Thus, individuals during our study performed unequally and may have differed in the behavioural mechanisms applied during the task.

Evidence for scent cues?

If bats were leaving some scent cue by themselves then the ability to avoid previously visited feeders would not be an effect of memory but of sensory discrimination. Our general observations speak against this possibility. Bats hover in the air while feeding and only the tongue and frontal head make contact with the feeder. After habituation to feeders we normally did not observe inspection behaviour that would be required for olfactory sampling. Instead, bats approached chosen feeders directly and without hesitation. Nevertheless, to examine further the possibility of putative olfactory cues we performed the following analysis. It is unlikely that a hypothetical olfactory cue would be individual-specific. If scent-marking behaviour had evolved, bats in nature should not only avoid flowers visited by themselves but also every flower visited recently by any other bat. Refill intervals in natural flowers often range from 20 min to about 1 h (von Helversen, 1993; Winter and von Helversen, 2001; von Helversen and Winter, 2003) so a scent mark should persist over such a time interval in order to be useful.

During our experiments groups of three bats used the same array in an uninterrupted nightly cycle so different individuals fed from the array in repeated succession. Thus, if scent cues influenced feeder visitation we should expect feeder visits by any bat to influence the choice behaviour of its immediate successor at the array. We analysed our data for evidence of such an effect. We determined for each feeder for each trial if it had been visited in the preceding trial (always a different individual). This gave us four groups of feeders: feeders visited or not during the preceding trial and feeders visited or not during the succeeding trial. We then asked if the probability of visiting a feeder was affected by previous visitation by another individual. To exclude the potential effect of scent decay we only included pairs of trials separated by a maximum time span of 20 min between visits by the two individuals. Analysis was restricted to data after trial 10 and, within individual data sets, to feeders visited at least three times during trials 11–20. The results of our analysis did not produce any evidence for an influence of scent cues. The ratio of visits to feeders that had or had not been visited by the previous bat was 1.02 (± 0.18 S.D.). This was not significantly different from 1.0, the ratio expected for random choice between feeders that had been either visited or not visited by the predecessor (t -test, $t=0.425$, $d.f.=10$, $P=0.68$). Scent cues do not appear to have influenced feeder choice during our experiments.

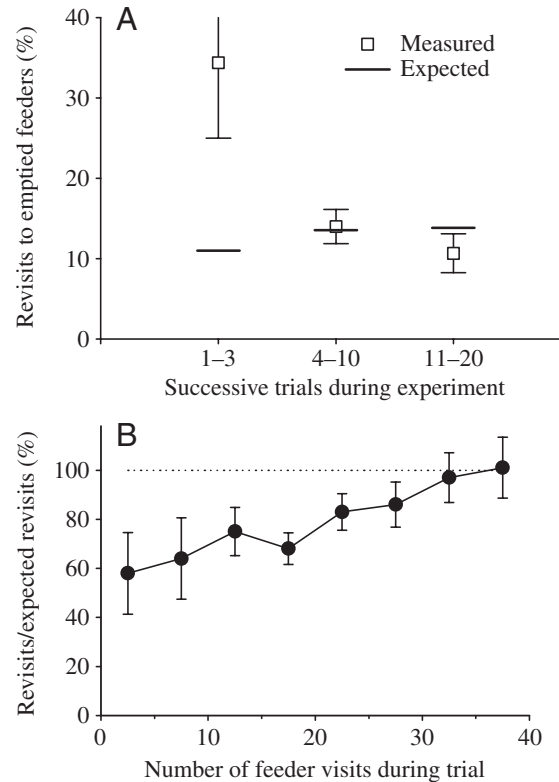

Fig. 7. Revisits to previously emptied feeders in comparison to revisit frequency expected under random choice of feeders. (A) Between-trials: revisits during successive trials of the experiment. The drop within the first three trials indicates the transition from a brief win-stay to a win-shift strategy. For calculations, see text. Revisits expected under random choice (line symbol) are a function of the number of feeders emptied during a trial; this number increases (from trials 1–3 to trials 11–20) as more feeders are emptied within a trial. Error bars are 95% confidence intervals of the difference (paired t -test) between measured revisits and revisits expected assuming random choice of feeders. Differences were significant for trials 1–3 ($t=5.3$, $d.f.=14$, $P<0.001$) and trials 11–20 ($t=-2.8$, $d.f.=15$, $P=0.014$) but not for trials 4–10 ($t=0.5$, $d.f.=15$, $P>0.05$). Data shown are means of the individual values for $N=16$ individuals (one individual with less than 20 visits during each of trials 1–3 was excluded from this specific analysis). (B) Within-trials: ratio of revisits to revisits expected under random choice within a trial. Data are for successive blocks of five visits within trials (based on trials 11–20, $N=16$ individuals, for calculation, see text). Data shown are the means of individual values (\pm S.E.M.). Frequency of revisits differed significantly from random expectation up to the 20–25th visit during a trial (Wilcoxon test, $Z>2.1$, $N=16$, $P<0.05$).

Recency and working memory capacity

If bats had selected feeders at random then revisits should have followed the current ratio between emptied and full feeders. The results in Fig. 7 and the analysis given above show that bats avoided revisits. Since bats did not appear to have used a simple rule of movement at the array they must have remembered the positions of feeders emptied in order to avoid those positions during later visits during the same trial (spatial working memory; Olton and Samuelson, 1976). This memory

must have formed rapidly as feeder visits lasted only 0.8 s (hovering duration) to 2 s (time span to next visit; Fig. 6).

If bats did remember feeders visited then it might be expected that feeders emptied recently are better remembered and more successfully avoided than those feeders emptied longer ago (recency effect). After a visit to a feeder a bat has n opportunities during the next n visits of a trial to revisit this particular feeder. Accordingly, there are $n-1$ opportunities to return two or more visits later to an emptied feeder, and $n-2$ opportunities to return three or more visits later during each sequence of n visits following the first visit and so on. We calculated the number of opportunities that each bat had for each length of inter-visit interval from the number of visits made during each trial. We then summed the number of revisits and the number of opportunities over blocks of five inter-visit interval lengths and calculated the percentage of opportunities taken by each bat for each block of intervisit intervals (Shettleworth and Krebs, 1982). We performed these calculations separately for the initial trials 1–3 and the later trials 11 to 20 (Fig. 8A). A consequence of the initial win-stay strategy was a strong tendency in trials 1–3 to revisit feeders that had recently been emptied. So there were many revisits during short intervisit intervals during those trials. By trials 11–20, this win-stay effect was no longer detectable. Surprisingly, however, was the flat continuation of the curve in Fig. 8A. In general, recent events are often remembered better than events from longer ago, the so-called recency effect (Shettleworth, 1998). For our data, we had expected that for visits to feeders that had occurred longer ago (long inter-visit interval) bats would eventually show disproportionately higher rates of revisitation errors, indicating that they were forgetting their initial visit. However, the expected increase in the number of errors after long intervisit intervals is not apparent in the data (Fig. 8A). This differs from the findings of other authors performing similar experiments with other organisms (Fig. 8B, Discussion).

Discussion

Experimental system

The system described here allows the simulation of a complex naturalistic environment with variable and dynamic conditions of food or water availability and dependable data collection over the entire daily activity phase. In the case of a nectar feeding bat this may amount to up to 3000 feeder visits in 12 h, which could hardly be recorded through direct observation or video analysis of these highly mobile, nocturnal animals (duration of one visit ~200–1200 ms). Direct animal contact is minimal because animals must be handled only at the beginning and the end of an experimental series lasting up to several weeks. Presence of personnel during experimental tests is rarely necessary. A further benefit of the system is easy adjustment of the scheduling of trials to the natural activity rhythms of the animals. Flower bats, for example, alternate naturally between active flying and rest phases, with a ratio of 1:2 during the night. (Winter and von Helversen, 2001). By

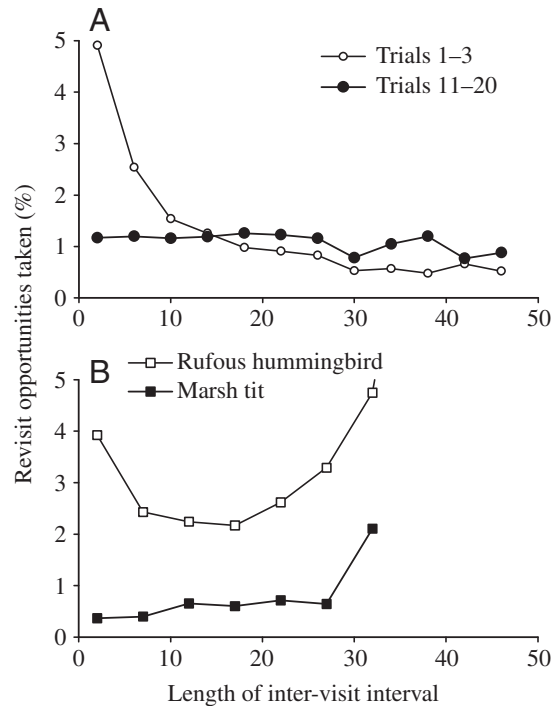

Fig. 8. Proportion of revisits relative to the potential number of revisits for a given inter-visit interval during a specific trial (for calculation, see text). (A) Data from this study for *Glossophaga soricina* ($N=17$ individuals). The high values during trials 1–3 (open symbols) are an effect of the initial win-stay strategy of revisiting just-emptied feeders (see Fig. 7A). (B) Equivalent data for marsh tits (*Parus palustris*; Shettleworth and Krebs, 1982) and rufous hummingbirds (*Selasphorus rufus*; Sutherland, 1986) shown here for comparison (see Discussion).

releasing each animal to the feeder array for approximately one third of the time alternately, high animal activity in the test arena of the feeder array can be maintained almost continuously.

The smooth operation of experiments with this set up depends not only on technology, but also on cooperation by the animals. An animal that delays its return to the cage will, in consequence, set back the experiment for all other animals. During our experiments some groups of three bats completed a series of 20 interleaved trials in 7 h, while others required as much as 12 h because some individuals returned late. Preliminary experiments taught us that reward quantity in the cages and the feeder array must be well balanced for smooth operation (as described in the Materials and methods section) as bats may otherwise prefer to remain in one of the experimental compartments (cage or feeder array). The system described here can easily be adapted for other animal taxa without major changes to the basic principle of operation. The hanging perch for bats may be replaced by an erect perch for birds. For mice, we have used feeders as quantitative water dispensers (Y.W., unpublished). The system is a dependable means to effect completely automated data collection in behavioural tests on a wide variety of animals.

Spatial working memory

To maximize their rate of food intake while foraging or maximize their foraging efficiency, bats had to avoid the positions of feeders already emptied, as feeders gave only a single reward during a trial. Food was only delivered after arrival so bats could not sense its presence beforehand. Two lines of evidence support the idea that bats during our experiments remembered the spatial positions where they had fed. Initially, bats revisited emptied feeders significantly more often than expected under random choice (win-stay behaviour; Fig. 7A, trials 1–3). Many of these revisits occurred after 5–10 intermittent visits to other feeders rather than directly following the initial visit. This is apparent from Fig. 8A where the rate of revisits during trials 1–3 was still higher even after 5–10 intervening visits to other feeders. This provides first evidence that bats must have remembered the spatial positions visited recently. This result cannot be explained by a simple movement pattern. A forager using area-restricted search remains in the vicinity of a good location. The bats, however, tended to jump between positions within the feeder array, often moving more than half its width between successive visits (Fig. 6A). Furthermore, these distances were larger after a reward than after an unsuccessful visit. Area-restricted search predicts the opposite.

Bats changed their behaviour from win-stay to win-shift within 4–10 trials (Figs 7A,8A). Thereafter they significantly avoided emptied feeders (Fig. 7B). However, did bats avoid empty feeders by remembering their spatial locations? At the 64-feeder array, bats could have easily obtained a high rate of success if they had systematically emptied feeders starting at one corner and going up- or downwards in rows, using thigmotactic or chaining behaviour. This, however, is not what they did. On average, the next feeder visited was 4.6 feeder positions away from the previous one (Fig. 6A). Thus, bats did not move through the array by applying the simple search rule of systematically visiting adjacent feeders but instead tended to move across large gaps of, on average, half the extent of the total feeder array. This is strong evidence that bats remembered the spatial locations visited and therefore possess a well-developed spatial working memory. This conclusion is further corroborated by our failure to find evidence for scent cues influencing feeder choice. During our experiments the same array was used by several bats in an uninterrupted nightly cycle so different individuals fed from the array in repeated succession. Thus if scent cues had influenced feeder visitation we should expect feeder visits by a bat to influence the choice behaviour of its immediate successor at the array. Our analysis did not produce any such evidence. While data on movement patterns within natural inflorescences are still scant, observations of *Glossophaga commissarisi* during inspection flights between adjacent inflorescences of a rainforest vine also did not indicate systematic movement between adjacent neighbours (von Helversen and von Helversen, 2003).

Previous authors have tried to show the use of spatial working memory by examining data for an effect of recency.

If locations of emptied feeding sites are remembered, then one might expect that recently experienced feeding sites are better remembered and more successfully avoided than those emptied longer ago (recency effect; Shettleworth, 1998). Two examples from the literature are seed-storing marsh tits that remembered the sites of food recovery (Shettleworth and Krebs, 1982) and hummingbirds remembering the positions of feeders already emptied (Sutherland, 1986). In the marsh tit study, the percentage of 'revisit opportunities taken' (see Materials and methods; Fig. 8B) was below 1%, but rose to significantly higher values when more than 29 visits had passed since initial seed recovery (Shettleworth and Krebs, 1982). Similarly, the rate of 'revisit opportunities taken' by hummingbirds was initially between 2 to 5%, but rose to values between 10% to 30% after 20–30 intervening visits to other feeders (Fig. 8B). Thus, in both bird species spatial working memory is of sufficient capacity to remember the sites of feeding actions visited about 30 visits earlier.

In the present study, a recency effect was not apparent up to the 45th visit during trials (Fig. 8B). By comparison, the marsh tits were actually doing slightly better than the bats (lower proportion of revisit opportunities taken, Fig. 8A,B) but only until about 30 visits. However, one should note that, even within a species, the quantitative characteristics of memory should vary with the details of what is remembered. For instance, spacing between feeders (Brown, 1994), the numerical size of the array, whether feeders are arranged in three dimensions or two (as here), or the actual time interval that has passed (in this study always below five minutes), etc. While the bat curve remained flat in our experiment (Fig. 8A) we do not know if and under which conditions it would eventually rise. So the change in pattern within the bat data from trials 1–3 to 11–20 is perhaps of equal interest as the difference from the two sets of bird data.

Olton (1977) suggested that rats can hold visits to 25–30 different arms in their spatial working memory based on work in a 17-arm maze, and Roberts (1979) reported good performance in a hierarchical maze with 32 different locations (8 arms that continue in two successive bifurcations). The present data indicate that nectar-feeding bats at least match the performance reported for rats and they suggest the possibility that the spatial working memory capacity of these flower-visiting specialists may surpass that of rats.

From an ecological point of view, a well-developed spatial working memory would be expected for a nectar-feeding flower visitor (Cole et al., 1982; Armstrong et al., 1987). Since the nectar of flowers is often replenished rapidly, individual flowers are worth revisiting but only after a sufficient time interval has elapsed. This creates the need to remember past actions of flower visitation in order to space visits adequately. The natural problem faced by the bats is, thus, not only spatial but also temporal. It is worth noting that within the speciose family of neotropical phyllostomid bats, the volume of the hippocampus is greatly enlarged in the nectar-feeders, surpassing the volume of closely related but insect-feeding species by 50–100% (U. Kaupert and V. Winter, unpublished).

This indicates a neural adaptation to a trophic niche where spatiotemporal dynamics maintain resources (flower nectar) in continuous but tractable change and where behavioural optimisation should depend on rapid spatial learning and memory.

We are grateful to Lee Gass and Glenn Sutherland for generously sharing their experience and helping us to work out how to use the technology effectively. Hans-Ulrich Kleindienst provided his much appreciated technical expertise. This manuscript benefited from comments by Lee Gass, Ulf Tölch, Wolfgang Wickler, Lucie Salwiczek and two anonymous referees. Our study was supported by a grant from the Volkswagen Foundation.

References

- Armstrong, D. P., Gass, C. L. and Sutherland, G. D.** (1987). Should foragers remember where they've been? Explorations of a simulation model based on the behavior and energetics of territorial hummingbirds. In *Foraging Behavior* (ed. A. C. Kamil, J. R. Krebs and H. P. Pulliam), pp. 563-586. New York: Plenum.
- Baker, H. G. and Baker, I.** (1990). The predictive value of nectar chemistry to the recognition of pollinator types. *Israel J. Bot.* **39**, 157-166.
- Baron, G., Stephan, H. and Frahm, H.** (1996). *Comparative Neurobiology in Chiroptera* Basel, Boston, Berlin: Birkhäuser Verlag.
- Bolten, A. B., Feinsinger, P., Baker, H. G. and Baker, I.** (1979). On the calculation of sugar concentration in flower nectar. *Oecologia* **41**, 301-304.
- Brown, G. S.** (1994). Spatial association learning by rufous hummingbirds (*Selasphorus rufus*): effects of relative spacing among stimuli. *J. Comp. Psychol.* **108**, 29-35.
- Cole, S., Hainsworth, F. R., Kamil, A. C., Mercier, T. and Wolf, L. L.** (1982). Spatial learning as an adaptation in hummingbirds. *Science* **217**, 655-657.
- Eichenbaum, H. and Cohen, N. J.** (2001). *From Conditioning to Conscious Recollection: Memory Systems of the Brain* pp. 1-600. Oxford: Oxford University Press.
- Fry, S. N., Bichsel, M., Muller, P. and Robert, D.** (2000). Tracking of flying insects using pan-tilt cameras. *J. Neurosci. Meth.* **101**, 59-67.
- Gallistel, C. R. and Cramer, A. E.** (1996). Computations on metric maps in mammals: getting oriented and choosing a multi-destination route. *J. Exp. Biol.* **199**, 211-217.
- Gass, C. L.** (1977). A digital encoder for field recording of behavioral, temporal and spatial information in directly computer-accessible form. *Behav. Res. Meth. Instr.* **9**, 5-11.
- Gass, C. L.** (1978). Experimental studies of foraging in complex laboratory environments. *Am. Zool.* **18**, 729-738.
- Gerhardt, A., Carlsson, A., Ressemann, C. and Stich, K. P.** (1998). New online biomonitoring system for *Gammarus pulex* (L.) (Crustacea): *in situ* test below a copper effluent in south Sweden. *Environ. Sci. Technol.* **32**, 150-156.
- Hagstrum, D. W., Flinn, P. W. and Shuman, D.** (1996). Automated monitoring using acoustical sensors for insects in farm-stored wheat. *J. Econ. Entomol.* **89**, 211-217.
- Helversen, D. v. and Helversen, O. v.** (2003). Object recognition by echolocation: a nectar-feeding bat exploiting the flowers of a rain forest vine. *J. Comp. Physiol. A* **189**, 327-336.
- Helversen, O. v.** (1993). Adaptations of flowers to the pollination by glossophagine bats. In *Animal-Plant Interactions in Tropical Environments* (ISBN 3-925382-36-4) (ed. W. Barthlott), pp. 41-59. Bonn: Museum Koenig.
- Helversen, O. v. and Winter, Y.** (2003). Glossophagine bats and their flowers: cost and benefit for plant and pollinator. In *Ecology of Bats* (ed. T. H. Kunz and M. B. Fenton), pp. 346-397. Chicago: University of Chicago Press.
- Janson, C. H.** (1998). Experimental evidence for spatial memory in foraging wild capuchin monkeys, *Cebus apella*. *An. Behav.* **55**, 1229-1243.
- Jeffery, K. J.** (2003). *The Neurobiology of Spatial Behaviour* pp. 1-316. Oxford: Oxford University Press.
- Kao, S. D., Shaw, F. Z., Young, M. S. and Jan, G. J.** (1995). A new automated method for detection and recording of animal moving path. *J. Neurosci. Meth.* **63**, 205-209.
- Mauck, B. and Dehnhardt, G.** (1997). Mental rotation in a California sea lion (*Zalophus californianus*). *J. Exp. Biol.* **200**, 1309-1316.
- Olton, D. S.** (1977). Spatial memory. *Sci. Am.* **236**, 82-98.
- Olton, D. S. and Samuelson, R. J.** (1976). Remembrances of places past: spatial memory in rats. *J. Exp. Psychol. An. Behav. Processes* **2**, 97-116.
- Redish, D. A.** (1999). *Beyond the cognitive map: from place cells to episodic memory* pp. 1-420. Cambridge: MIT Press.
- Roberts, W. A.** (1979). Spatial memory in the rat on a hierarchical maze. *Learn. Motiv.* **10**, 117-140.
- Roberts, W. A.** (1984). Some issues in animal spatial memory. In *Animal Cognition* (ed. H. L. Roitblat, T. Bever and H. Terrace), pp. 425-443. Hillsdale, New Jersey: Lawrence Erlbaum Associates.
- Shettleworth, S. J. and Krebs, J. R.** (1982). How marsh tits find their hoards: the roles of site preference and spatial memory. *J. Exp. Psycho. An. Behav. Processes* **8**, 354-375.
- Shettleworth, S. J.** (1998). *Cognition, Evolution and Behavior* New York, Oxford: Oxford University Press.
- Sutherland, G.** (1986). *The role of spatial pattern learning in hummingbird foraging*. Master's Thesis. University of British Columbia.
- Sutherland, G. D. and Gass, C. L.** (1995). Learning and remembering of spatial patterns by hummingbirds. *Anim. Behav.* **50**, 1273-1286.
- Taylor, P. E., Haskell, M., Appleby, M. C. and Waran, N. K.** (2002). Perception of time duration by domestic hens. *Appl. An. Behav. Sci.* **76**, 41-51.
- Thiele, H. and Winter, Y.** (2004). Hierarchical strategy for relocation of food targets in flower bats: spatial memory versus cue-directed search. *An. Behav.* dx.doi.org/10.1016/j.anbehav.2004.05.012.
- Trullier, O., Wiener, S. I., Berthoz, A. and Meyer, J. A.** (1997). Biologically based artificial navigation systems: Review and prospects. *Prog. Neurobiol.* **51**, 483-544.
- Tsibulsky, V. L. and O'gower, A.** (2002). An automated method for measuring the cocaine priming threshold. *Drug Alcohol Depend.* **66**, 202.
- Wang, R. F. and Spelke, E. S.** (2002). Human spatial representation: Insights from animals. *Trends Cog. Sci.* **6**, 376-382.
- Winter, Y. and Helversen, O. v.** (2001). Bats as pollinators: foraging energetics and floral adaptations. In *Cognitive Ecology of Pollination* (ed. L. Chittka and J. D. Thomson), pp. 148-170. Oxford: Oxford University Press.
- Young, M. S., Li, Y. C. and Lin, M. T.** (1993). A modularized infrared light matrix system with high-resolution for measuring animal behaviors. *Physiol. Behav.* **53**, 545-551.