

## METHODS & TECHNIQUES

### A simple and affordable calorespirometer for assessing the metabolic rates of fishes

M. D. Regan\*, J. M. Gosline and J. G. Richards

Department of Zoology, University of British Columbia, 6270 University Boulevard, Vancouver, BC, Canada, V6T 1Z4

\*Author for correspondence (regan@zoology.ubc.ca)

#### SUMMARY

**Calorimetry is the measurement of the heat liberated during energy transformations in chemical reactions. When applied to living organisms, it measures the heat released due to the energy transformations associated with metabolism under both aerobic and anaerobic conditions. This is in contrast to the often-used respirometric techniques for assessing energy turnover, which can only be used under fully aerobic conditions. Accordingly, calorimetry is considered the ‘gold standard’ for quantifying metabolic rate, yet despite this, it remains a seldom-used technique among comparative physiologists. The reasons for this are related to the expense and perceived difficulty of the technique. We have designed and constructed an inexpensive flow-through calorespirometer capable of detecting rates of metabolic heat loss and oxygen consumption ( $\dot{M}_{O_2}$ ) in fish under a variety of environmental conditions over long-term experiments. The metabolic heat of the fish is detected as a voltage by a collection of Peltier units wired in series, while oxygen optodes placed on the inflowing and outflowing water lines are used for the calculation of  $\dot{M}_{O_2}$ . The apparatus is constructed in a differential fashion to account for ambient temperature fluctuations. This paper describes the design and construction of the calorespirometer for ~\$1300 CDN. Using the goldfish (*Carassius auratus auratus*), we show that the calorespirometer is sensitive to changes in metabolic rate brought about by pharmacological manipulation and severe hypoxia exposures.**

Key words: calorespirometry, calorimetry, fish, heat production, metabolism, respirometry.

Received 3 July 2013; Accepted 9 September 2013

#### INTRODUCTION

The accurate measurement of metabolic rate has tremendous value across many disciplines in the life sciences. The rate at which an organism consumes and utilizes energy provides insight into its biology from the level of its cells to its ecology (Hochachka and Somero, 2002; Brown et al., 2004). The most widely used method for assessing metabolic rate is through the measurement of oxygen consumption rate ( $\dot{M}_{O_2}$ ), which, under aerobic conditions, provides a reasonably good estimate of metabolic rate. However, under circumstances like hypoxia, where the metabolic rate of an organism cannot be solely supported by aerobic metabolism, and anaerobic processes are utilized to buffer ATP turnover, measurement of  $\dot{M}_{O_2}$  could drastically underestimate metabolic rate. This is most evident in cases of anoxia-tolerant organisms like the painted turtle (*Chrysemys picta*), crucian carp (*Carassius carassius*) and goldfish (*Carassius auratus auratus*), where attempts to quantify metabolic rate *via* respirometry in anoxia are futile because of the organism's complete reliance on anaerobic processes to support energy turnover. Like aerobic pathways, however, these pathways yield heat as a by-product, and the total amount of heat lost by an animal to its environment is proportional to its total energy turnover (minus that conserved in carbon bonds) (Mendelsohn, 1964; Mclean and Tobin, 1987; Kaiyala and Ramsay, 2011). Measuring this heat *via* calorimetry is therefore an effective way of estimating an animal's metabolic rate in situations where aerobic metabolism may be compromised.

Despite direct animal calorimetry being the ‘gold standard for quantifying the fire of life’ (Kaiyala and Ramsay, 2011), it is a seldom-used technique owing to its reputed difficulty and expense

when compared with respirometry. These difficulties are especially true when working with ectothermic animals like fish, whose lower metabolic rates produce less heat compared with similarly sized endotherms. Measuring these low levels of heat requires an especially sensitive calorimeter and, to date, these have been extremely expensive to purchase. Efforts have been made over the years to produce inexpensive systems to measure heat in fish (Davies, 1966; Stevens and Fry, 1970), but they have not been described in sufficient detail to facilitate their reconstruction. With high-density thermocouple Peltier units being widely available, it should be possible to construct a relatively simple and inexpensive calorimeter of high sensitivity. Here, we describe the construction and testing of such an apparatus, capable of converting a fish's metabolic heat to a voltage through the use of Peltier units and the thermoelectric effect (more specifically, the Seebeck effect). Furthermore, the fish chamber is designed to operate under flow-through conditions to enable environmental manipulations and the simultaneous measurement of inflowing and outflowing partial pressure of  $O_2$  ( $P_{O_2}$ ), which can be used to calculate  $\dot{M}_{O_2}$  (hence, calorespirometer). We tested the calorespirometer's function using goldfish, a species that is well known to undergo metabolic rate suppression in response to hypoxia/anoxia exposure (van Waversveld et al., 1988; Addink et al., 1991; Stangl and Wegener, 1996; Richards, 2009).

#### MATERIALS AND METHODS

##### Theory and overview

The Seebeck effect allows a heat flux to be converted to a voltage as it passes through a thermally conductive element such as a

thermocouple. Peltier units are composed of a number of antimony telluride thermocouples connected in series that, with a Seebeck coefficient of  $213 \mu\text{V K}^{-1}$ , are highly sensitive to temperature change. In building our calorimeter, we placed a collection of Peltier units between a small fish/reference chamber and a large mass of aluminium so that the metabolic heat produced by the fish would flow through the Peltier units and into the mass of aluminium. The calorimeter was assembled in a differential fashion with two identical fish/reference chambers attached on either side of the aluminium mass. To measure metabolic heat loss from the fish, the two chambers were treated identically apart from the presence of a fish (or resistor; see 'Heat calibration and measurements' section below) in one side, and we monitored the net voltage between the two chambers. This differential configuration accounted for any fluctuation in ambient temperature. Below, we detail the construction of the apparatus and its major components, and explain how it was assembled to optimize performance. A complete list of its essential and accessorizing components and their costs is shown in Table 1.

### Calorimeter

For this section, 'calorimeter' will refer exclusively to the component of the calorimeter responsible for the detection of heat and its conversion to a voltage. This component, shown in Fig. 1A,B, was assembled symmetrically with two identical sides centred on a block of aluminium ( $98 \times 48 \times 48 \text{ mm}$ ). Two Peltier units ( $\sim 40 \times 40 \times 4.7 \text{ mm}$ , 127 couples; Custom Thermoelectric Peltier module 12711-5L31-03CQ, Bishopville, MD, USA) were affixed to each side of this block using an ultra-thin layer of silver conductive epoxy (MG Chemical no. 8331, Surrey, BC, Canada) and connected in series so as to maximize the voltage reading (Fig. 1A). A brass block ( $\sim 78 \times 26 \times 26 \text{ mm}$ ) was affixed to the opposite side of each group of Peltier units using silver conductive epoxy. Brass was ideal for this component as its hardness and machinability allowed for especially thin walls and its high thermal conductivity optimized heat flow. The brass blocks had a 25 mm diameter bore into which a fish or reference chamber could be inserted. Together with the Peltier units and the brass blocks, the central block of aluminium was bolted to another aluminium block ( $\sim 98 \times 152 \times 48 \text{ mm}$ ) into which two

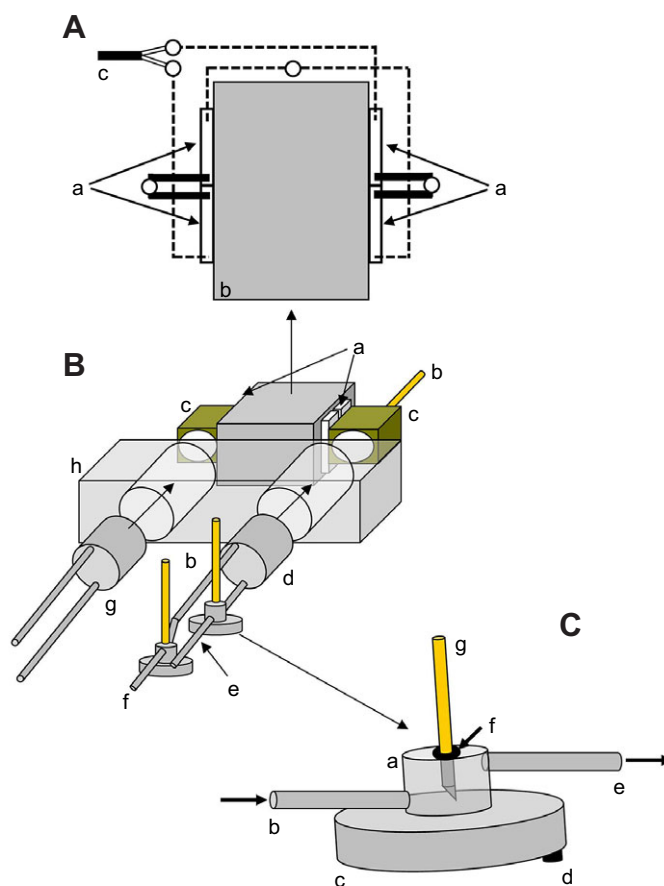

Fig. 1. (A) Wiring diagram of the four Peltier units (fish chamber side on right, reference chamber side on left). Dashed lines represent positive wires, thick black lines (towards the centre) represent negative wires and white circles represent the soldered junctions between wires (each affixed to the aluminium mass; see Materials and methods for details). a, Peltier units; b, central aluminium block; c, pure copper lead to voltmeter. (B) Schematic diagram of the functional component of the calorimeter. a, Peltier units; b,  $P_{\text{O}_2}$  optodes (highly simplified; see C below); c, brass blocks with a 25 mm diameter bore; d, 32 ml fish chamber; e, inflowing stainless steel water line; f, outflowing stainless steel water line; g, 32 ml reference chamber; h, aluminium block. This portion of the calorimeter is embedded within a 40 kg mass of aluminium located within a highly insulated ice chest. (C) Detailed schematic diagram of the  $P_{\text{O}_2}$  optode chamber. a, 1 ml stainless steel water chamber; b, inflow water line; c, Plexiglas base; d, affixed rubber stopper to tilt chamber and promote the exit of any gas bubbles; e, outflow water line; f, rubber gasket; g,  $P_{\text{O}_2}$  optode tip.

cylinders were bored ( $\sim 25 \text{ mm}$  diameter) and through which the fish chamber and reference chamber could be inserted into and removed from the calorimeter's brass blocks (Fig. 1B).

### Fish and reference chambers

Identical 32 ml flow-through chambers were constructed to serve as the fish chamber and the reference chamber (Fig. 1B). These chambers were made of stainless steel tubing ( $\sim 77 \text{ mm}$  length, 25 mm o.d., 24 mm i.d., 0.5 mm wall thickness; McMaster-Carr no. 6622K152, Aurora, OH, USA), with a stainless steel cap of 0.5 mm thickness permanently welded to the upstream end of the chamber. Inserted through this cap were stainless steel inflow and outflow water lines (1 mm o.d., 0.8 mm i.d., 0.1 mm wall thickness), the inflow water line running along the chamber's bottom all the way to the downstream end, and the outflow water line situated at the

Table 1. Required components and costs for construction of the calorimeter described in Materials and methods

Components	Total cost (\$ CDN)
<b>Calorimeter-specific components</b>	
Aluminium blocks (8)	648
Brass rod (1)	125
Peltier units (4)	78
Ice chest (2)	140
Stainless steel tubing (for chambers)	47
Stainless steel tubing (for water lines)	60
Materials for $P_{\text{O}_2}$ optode chambers (2)	75
Plexiglas caps (2)	8
Silver conductive epoxy	5
Styrofoam insulation	80
<b>Additional components</b>	
Voltmeter and copper lead (1)	—
Computer and data acquisition system	—
$P_{\text{O}_2}$ optodes, hardware, software (3)	—
Peristaltic pump and tubing (1)	—
Gas mixer (1)	—
Temperature-controlled environment chamber	—
Machining costs	—
<b>Total</b>	<b>1266</b>

Prices are in Canadian dollars (\$ CDN); taxes not included.

chamber's top and mounted flush with the stainless steel cap at the upstream end of the chamber. The water lines were oriented this way to optimize mixing within the chamber and to allow an easy path of exit for any gas bubbles that may enter the chamber. Finally, a removable Plexiglas cap equipped with a rubber gasket was placed at the downstream end of the chamber through which the fish could be inserted and removed. This cap could also accommodate a  $P_{O_2}$  optode (Ocean Optics OR125, Dunedin, FL, USA) that was used to measure the  $P_{O_2}$  within the chamber. Apart from this optode, the fish chamber and reference chamber were identical.

### Respirometer

For this section, 'respirometer' will refer exclusively to the component of the calorespirometer responsible for the measurement of  $P_{O_2}$  and determination of  $\dot{M}_{O_2}$ . This component was built in a flow-through fashion and incorporated exclusively on the fish chamber side of the calorimeter. Small stainless steel chambers of 1 ml (Fig. 1C) were built to accommodate  $P_{O_2}$  optodes (Ocean Optics OR125) on both the inflow and outflow water lines immediately adjacent to the bored-out aluminium block (i.e. as close to the fish chamber as possible), and the difference between the  $P_{O_2}$  values measured by these optodes enabled calculation of the fish's  $\dot{M}_{O_2}$ .

No heat or electrical signals from the activated  $P_{O_2}$  optodes could be detected by the calorimeter, thus their use did not affect measurements of metabolic heat loss.

### Setup and optimization

To provide a thermally stable environment for the calorespirometer, it was placed within an insulated ice chest (Coleman 6-Day Xtreme, Golden, CO, USA) inside an additional enclosure (foam insulation, 5.08 cm thickness), located within a temperature-controlled ( $20 \pm 0.1^\circ\text{C}$ ) environmental chamber measuring  $3 \times 3 \times 2.5$  m. The insulated ice chest was lined with aluminium blocks totalling  $\sim 40$  kg, and the calorespirometer was placed in the centre of the chest. The aluminium was used as a heat sink, drawing heat from the fish and reference chambers through the Peltier units. The aluminium's high thermal inertia, a function of its mass, thermal conductivity ( $237 \text{ W m}^{-1} \text{ K}^{-1}$ ) and (molar) heat capacity ( $24.2 \text{ J mol}^{-1} \text{ K}^{-1}$ ), made it an especially effective heat sink and ensured the Peltier units accounted for as much of the fish's metabolic heat as possible.

As heat from the chambers flowed through the Peltier units, the net voltage was measured using a Keithley Model 147 nanovoltmeter (Cleveland, OH, USA). The leads from the Peltier units were soldered to the pure copper lead from the voltmeter and this junction was affixed to the aluminium mass using electrical tape to minimize

its possible (albeit small) effect on the measured voltage. The amplified signal was then digitally converted using a DATAQ DI-148 data acquisition system (Akron, OH, USA) and recorded on a Dell Precision M4300 laptop computer using DATAQ WinDaq software.

### Water supply and gas mixing

The water supplying the fish and reference chambers was sourced from a common 2 l recirculating volume. This volume was held in an insulated ice chest identical to the one housing the calorespirometer (minus the aluminium) and placed adjacently. Water was drawn out of the beaker by a peristaltic pump (Gilson Minipuls 3, Middleton, WI, USA), pushed into a gas equilibration chamber (see below), and then into the stainless steel tubing supplying the fish and reference chambers. Water flowed into and out of the chambers as described previously, and was emptied into the original 2 l beaker for recirculation.

To manipulate the gas tension in the fish and reference chambers, gas mixing was done using a precision gas mixer (Corning 192, Medfield, MA, USA) and the mixed gas was equilibrated with the water supply in two ways. First, the mixed gas was bubbled into the 2 l recirculating supply volume, and second, the mixed gas flowed into a 1.5 l glass gas equilibration chamber within which the supply water flowed through Silastic tubing before flowing into the stainless steel tubing supplying the fish and reference chambers (Fig. 2).

### Heat calibration and measurements

To calibrate the calorimeter, we used three different resistors [9890, 19,980 and 39,560  $\Omega$ ; 5% tolerance; resistance measured using a Fluke 73 multimeter (Everett, WA, USA) whose accuracy was calibrated using 16 different resistors of 1% tolerance] and the following equation:

$$\dot{Q} = V^2 / R, \quad (1)$$

where  $\dot{Q}$  is heat flow (in watts),  $V$  is voltage applied to a resistor (in volts) and  $R$  is the resistance of the resistor (in ohms). The resistors were each embedded in an epoxy-filled glass test tube to protect them from the water. During calibration, one of the glass/epoxy-embedded resistors was placed into the fish/reference chamber, and the whole unit inserted into the calorespirometer and held under experimental conditions (water flow rate of  $22 \text{ ml h}^{-1}$ ; normoxia; inflow, chamber and outflow  $P_{O_2}$  optodes running) in order to account for any lost metabolic heat owing to the flow-through design. A voltage [measured at 4.98 V and produced by a

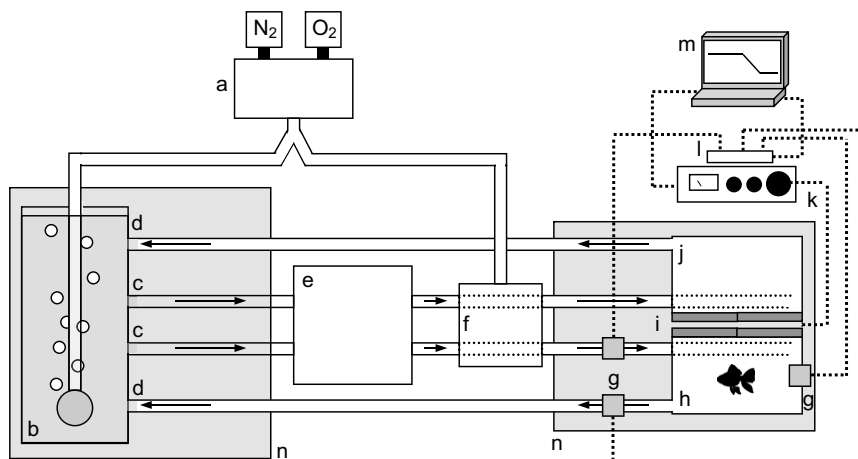

Fig. 2. Two dimensional schematic diagram detailing the calorespirometric setup. a, precision gas mixer; b, 2 l water volume supplying the fish and reference chamber; c, inflowing water lines; d, outflowing water lines; e, peristaltic pump; f,  $P_{O_2}$  equilibration chamber; g,  $P_{O_2}$  optodes; h, fish chamber; i, Peltier units; j, reference chamber; k, nanovoltmeter; l, data acquisition system; m, data acquisition computer; n, insulated ice chests. The calorespirometer (including  $P_{O_2}$  optodes) and water supply are housed within ice chests surrounded by foam insulation, which are themselves within a thermally regulated environmental chamber with ambient fluctuations of not more than  $0.1^\circ\text{C}$ . All heat-producing electrical equipment is housed outside the insulated ice chests.

C-TON Industries PW2-5 model power supply (Memphis, TN, USA) via a two wire system of negligible resistance ( $<0.35 \Omega$ ) when compared with the resistances of the resistors] was applied to the resistor, yielding heat flows of 2.528, 1.251 and 0.632 mW for the 9890, 19,980 and 39,560  $\Omega$  resistors, respectively. Once the measured voltage from the calorespirometer stabilized, it was recorded. Calibration with each resistor was performed three times and a calibration curve relating applied heat (in watts) to measured voltage was constructed and used to convert the metabolic heat of the fish, measured in millivolts, to milliwatts.

#### Oxygen consumption measurements

Oxygen consumption rates (moles of  $O_2$  consumed per hour per gram of tissue) were calculated from measurements of inflow and outflow  $P_{O_2}$ , water flow rate and animal mass according to the Fick principle:

$$\dot{M}_{O_2} = (\Delta P_{O_2} \times \alpha_{O_2} \times \text{flow}) / \text{animal mass},$$

where  $\Delta P_{O_2}$  is the difference in  $P_{O_2}$  between inflowing and outflowing water (in torr),  $\alpha_{O_2}$  is the solubility coefficient of  $O_2$  in water at the experimental temperature ( $1.8230 \mu\text{mol Torr}^{-1} \text{ l}^{-1}$  at  $20^\circ\text{C}$ ), flow is measured in  $\text{l h}^{-1}$  and animal mass is measured in grams. Partial pressure measurements in Torr were later converted to kPa.

#### Experimental animals

Goldfish, *Carassius auratus auratus* (Linnaeus 1758), of  $0.756 \pm 0.087$  g (mean  $\pm$  s.e.m.,  $N=5$ ) wet body mass were acquired from a commercial fish dealer and held at the Department of Zoology's Aquatic Facility at The University of British Columbia (Vancouver, BC, Canada). Fish were held at a stocking density of  $<0.4 \text{ g l}^{-1}$  in a 761 recirculating system and maintained in well-aerated, dechlorinated City of Vancouver tap water at  $20^\circ\text{C}$  under a 12 h:12 h light:dark cycle. Water in the recirculating system was replaced every 7–10 days. Fish were fed to satiation daily (Nutrafin Max Goldfish Flakes) except 24 h before being transferred to the calorespirometer, during which period feeding was suspended. The University of British Columbia Animal Care Committee approved all procedures involving fish.

#### Experimental protocols

Before each experiment, the  $P_{O_2}$  optodes were calibrated in air and 100% nitrogen. A single goldfish was then inserted into the fish chamber via the removable cap, and the chamber was sealed and slid into place within the calorespirometer's brass block. The peristaltic pump was turned on, supplying both fish and reference chambers with oxygenated water at a rate of  $22 \text{ ml h}^{-1}$ . Water temperature was maintained at  $20^\circ\text{C}$  throughout all experimental trials. The fish was allowed to habituate to the chamber for 16–18 h, which allowed sufficient time for both the thermal equilibration of the calorespirometer and the recovery of the fish from handling stress. After the habituation period, we conducted several experiments designed to test the calorimeter's function. To ensure it was capable of detecting variation in metabolic heat produced by the fish, we used carbonyl cyanide 4-(trifluoromethoxy) phenylhydrazone (FCCP; Sigma-Aldrich C2920, St Louis, MO, USA) in an attempt to increase metabolic rate via mitochondrial uncoupling, and benzocaine (Sigma-Aldrich E1501), an anaesthetic, to decrease metabolic rate. These experiments were repeated three times. The next set of experiments was carried out to ensure the apparatus was capable of detecting the previously observed  $O_2$ -dependent changes in metabolic heat produced by goldfish (van

Waversveld et al., 1988; van Waversveld et al., 1989; Addink et al., 1991). Water  $P_{O_2}$  was decreased from  $\sim 40$  kPa to  $0\text{--}0.25$  kPa, where it was held for 1.5 h before being returned to normoxia. This experiment was repeated five times.

Although the baseline heat signal remained stable over the duration of each run, it fluctuated between runs by  $\pm 0.03$  mV. In order to accurately determine the baseline heat signal for each experiment, we introduced an overdose of anaesthetic in the fish chamber (final concentration  $\sim 300 \mu\text{mol l}^{-1}$  benzocaine) to kill the fish in the chamber at the end of the experiment. Heat loss from the fish quickly subsided after the addition of the anaesthetic, stabilizing at a baseline value within  $\sim 25$  min (preliminary experiments showed no further decrease in heat loss rate over 3 h). After  $\sim 1$  h of stable baseline reading, the fish was removed from the calorespirometer and the experiment concluded.

#### Data and statistical analysis

Statistical analyses consisted of one-way analysis of variance, performed using SigmaStat version 4.0.

### RESULTS AND DISCUSSION

#### Metabolic heat

The calorespirometer was both stable and sensitive. Under flow-through conditions of  $22 \text{ ml h}^{-1}$  and  $20^\circ\text{C}$  but without a fish present, heat flow measurements showed very small oscillations ( $\pm 0.35$  mW) around the baseline and there was no net drift in baseline heat detected over 72 h (data not shown). Changes in  $P_{O_2}$  of inflowing water (between 0 and 40 kPa) and turning the  $P_{O_2}$  probes on and off had no effect on heat flow (data not shown).

The heat calibration generated a linear relationship between applied wattage and measured voltage (Fig. 3; equation of the line  $\text{mV} = 0.1371 \text{ mW}$ ) that could be used to convert the metabolic heat of a fish, measured in millivolts, to milliwatts. The heat pulses also revealed the calorespirometer's sensitivity to be  $141.15 \mu\text{V mW}^{-1}$  at a water flow rate of  $22 \text{ ml h}^{-1}$ , a sensitivity in close agreement with that of the only known commercially available calorespirometer that can accommodate a fish (see Addink et al., 1991).

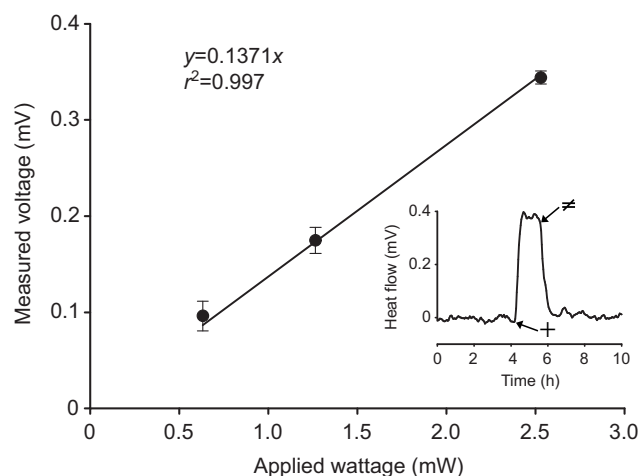

Fig. 3. Average voltage measured by the calorespirometer in response to known quantities of heat liberated within the fish chamber using a 5.0 V power supply (measured at 4.98 V) and resistors of 9890, 19,980 and 39,560  $\Omega$  resulting in a wattage of 2.528, 1.251 and 0.632 mW, respectively. The sample size was  $N=3$  for each average value, with error bars representing s.e.m. The trendline is forced through zero. Inset, a rectangular heat pulse of 2.528 mW switched on at '+' and switched off at '#'.

The next step involved inserting a fish into the fish chamber to determine whether the apparatus was capable of measuring its metabolic heat under fully oxygenated conditions. The representative trace in Fig. 4 shows that ~15 h were required for the fish to habituate to its new surroundings and for the calorespirometer to thermally equilibrate after insertion of the fish (at time zero in Fig. 4). During these preliminary trials, water  $P_{O_2}$  was maintained at ~40 kPa to ensure adequate oxygen delivery and compensate for the low water flow rate (22 ml h<sup>-1</sup>). The fish's rate of metabolic heat loss stabilized by 15 h and remained relatively constant at ~1.5 mW g<sup>-1</sup> (Fig. 4), with sporadic increases in heat probably due to episodes of activity.

To ensure we could detect variation in metabolic heat loss, pharmacological agents with known effects on metabolism were introduced into the fish and reference chambers by briefly transferring the inflow lines from the 2 l water supply beaker to a vessel holding the pharmacological agent. FCCP is an uncoupling agent that increases the permeability of the mitochondrial inner membrane, dissipating the proton gradient used to drive ATP production *via* oxidative phosphorylation. We predicted this would yield an increase in metabolic heat loss, and, in fact, sequential additions of 4  $\mu\text{mol l}^{-1}$  FCCP (up to 12  $\mu\text{mol l}^{-1}$  FCCP) resulted in incremental increases in heat loss, up to a 60.5±10.3% increase compared with controls ( $P<0.001$ ; Table 2). Similarly, benzocaine, a widely used anaesthetic, was administered in the same way with the prediction that it would decrease metabolic heat. A single dose of ~100  $\mu\text{mol l}^{-1}$  benzocaine resulted in a 68.6±5.1% decrease in heat loss compared with controls ( $P<0.001$ ).

Goldfish have been shown to reversibly suppress their metabolic rate by 60–70% when exposed to anoxia (van Waversveld et al., 1988; van Waversveld et al., 1989; Addink et al., 1991; Stangl and Wegener, 1996), and our results are consistent with these previous findings (Fig. 4, Fig. 5A). At the end of the 15 h habituation period, water  $P_{O_2}$  was decreased over 90 min to between 0 and 0.25 kPa. The fish was then held at this  $P_{O_2}$  for 1.5 h during which metabolic heat loss decreased and stabilized at an average value that was ~30% that of the average resting level (2.8 J g<sup>-1</sup> h<sup>-1</sup> at 0 kPa *versus* 9.3 J g<sup>-1</sup> h<sup>-1</sup> at 40 kPa; Fig. 5A). When  $P_{O_2}$  was returned to ~40 kPa, metabolic heat loss returned to levels that were equal to pre-hypoxia levels. Following a 2 h recovery period, the fish was killed with an overdose of anaesthetic to determine the baseline heat signal as described previously.

Table 2. Percentage increase in heat lost by goldfish when exposed to increasing concentrations of FCCP

	FCCP concentration ( $\mu\text{mol l}^{-1}$ )			
	Sham	4.0	8.0	12.0
Heat loss (%)	1.0±4.8	25.2±10.8*	47.9±3.5*	60.5±10.3*

All percentage increases are relative to resting levels of metabolic heat loss. Water temperature of 20°C. Sample size of  $N=3$  for each, with error bars representing s.e.m. Asterisks denote statistically significant difference from resting ( $P<0.001$ ).

### Oxygen consumption rate

Measured  $\dot{M}_{O_2}$  values from goldfish held in the calorespirometer showed similar responses to the measured heat fluxes discussed above. Specifically, high  $\dot{M}_{O_2}$  values were measured over the initial 5 h after the fish was introduced to the calorespirometer, gradually decreasing to stable levels after 12–15 h in the calorespirometer (Fig. 4). Our mass-specific routine  $\dot{M}_{O_2}$  values are higher than those reported elsewhere for goldfish (van Waversveld et al., 1988), but this variance is probably accounted for by differences in size (our fish are 12 times smaller than those used by van Waversveld et al.), fasting regime, and habituation time and conditions between the studies. Upon exposure to anoxia/hypoxia,  $\dot{M}_{O_2}$  fell to near-zero levels, returning to routine levels upon the reintroduction of  $O_2$  (Fig. 5B).

In order to maximize the sensitivity of our calorespirometer for heat detection, we used a low rate of water flow through the fish and reference chambers, which affected the time domain over which  $\dot{M}_{O_2}$  could be measured. After a change in inflowing  $P_{O_2}$ , about 60 min were required for the  $P_{O_2}$  in the outflowing water to stabilize and, thus, during this equilibration period, calculations of  $\dot{M}_{O_2}$  were inaccurate. Apart from this period, the fish's  $O_2$  consumption could be accurately and constantly measured in real time in parallel with its rate of metabolic heat loss. It is important to note that this ~60 min equilibration period was not needed for the measurement of metabolic heat; the calorimeter responded instantly to changes in heat and stabilized within ~25 min (Fig. 3, inset).

### Tips on effective calorespirometry

Despite the calorespirometer's straightforward design and assembly, much attention was needed when preparing the apparatus for

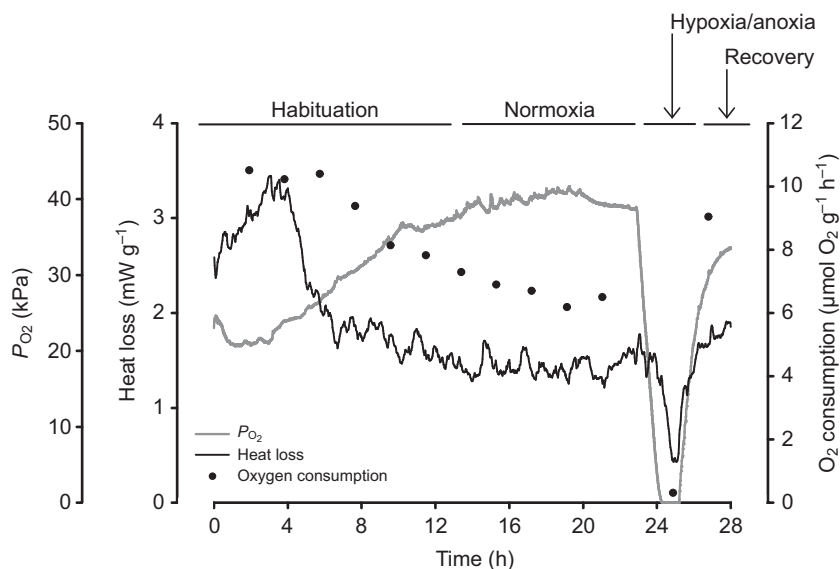

Fig. 4. A representative trace showing a 28 h experiment on a single goldfish of 0.628 g. The fish chamber containing the fish was inserted into the calorespirometer at time zero. This particular run saw a habituation period of ~14 h, a more stable normoxic period of ~10 h, an anoxic exposure of ~1.5 h and a recovery of ~2.5 h. The water temperature was 20°C throughout. The  $P_{O_2}$  reading is from the  $P_{O_2}$  optode located within the fish chamber (see Materials and methods for details).

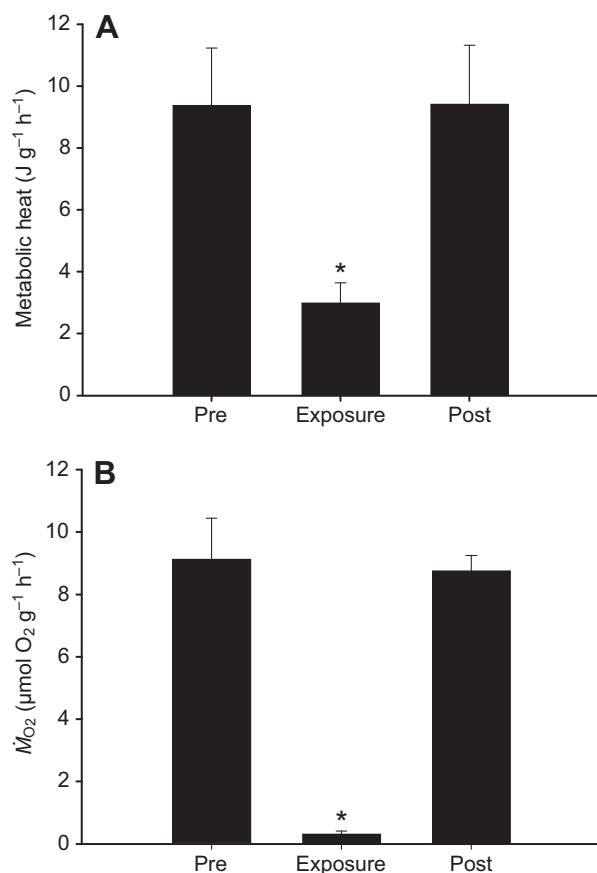

Fig. 5. Mean measurements of metabolic heat loss (A) and O<sub>2</sub> consumption rate (B) in goldfish held at 40 kPa P<sub>O<sub>2</sub></sub> before (Pre) and after (Post) exposure to hypoxia (0.25 kPa). Average wet body mass of fish was 0.756±0.087 g and water temperature was 20°C. The sample size was N=5 for each, with error bars representing s.e.m. Asterisks denote statistically significant differences (P<0.001).

experimental use. Central to most of this was the extreme thermal sensitivity of the Peltier units. The differential design of our calorimeter should theoretically account for fluctuations in ambient temperature, but effort was still required to ensure all heat produced by electrical equipment in the environmental chamber (e.g. computer, voltmeter, peristaltic pump, etc.) was evenly distributed across the enclosed, insulated ice chest. Fans and heat funnels were used for this, and any vulnerable parts on the insulated ice chest (especially drilled holes for the passage of water lines and electrical cables) were patched with form-fitting foam insulation. This was particularly important for holes in close proximity to the Peltier units. Although it was not a problem with our setup, care should also be taken to ensure the voltage reading is not being affected by electrical activity on the circuit into which the voltmeter is plugged.

The accurate and precise determination of a fish's metabolic rate demands a baseline heat signal that is known and stable. It is possible that with a highly controlled environment and a faithful duplication of experimental setup procedures and the orientation of all components, an identical inter-experiment baseline heat signal can be generated. However, despite our efforts, we noticed an inter-experiment fluctuation in baseline heat signal by ±0.03 mV (although mean intra-experimental baseline drift was negligible). This required the fish to be killed *via* an overdose of anaesthetic at the end of each experiment as described previously. Although this is not ideal, the accurate and precise determination of the fish's metabolic rate

required it. It is possible that this approach may be needed in other calorimeters built from this design.

Finally, a calorimeter like the one described here will inevitably come with a few limitations that need addressing. Firstly, the flow-through design that allows for environmental manipulation and long experimental durations means some of the metabolic heat produced by the fish will be washed downstream, resulting in a possible underestimation of its metabolic rate. This effect will be minimized through the use of a relatively low flow rate, and all but eliminated by performing the heat calibration process at the experimental flow rate (see Materials and methods). Secondly, the use of a low water flow rate could result in the accumulation of metabolic end products (e.g. CO<sub>2</sub>) in the fish chamber that could have their own effects on the organism. In our hands, measured P<sub>CO<sub>2</sub></sub> values never exceeded 1.1 kPa in a typical 24 h experiment and thus were not likely to have a negative effect on the fish's metabolic rate (Fry et al., 1947). Should the outflowing water contain high P<sub>CO<sub>2</sub></sub> or metabolic waste, a higher flow rate is recommended, though this will decrease the calorimeter's sensitivity. Thirdly, as discussed above, there are different time delays for the measurement of  $\dot{M}_{O_2}$  and heat loss that must be taken into account when assessing metabolic rate. In general, if both measurements are required, the time resolution for measurements will be of the order of 1–2 h. And finally, because of the long habituation time required for accurate measurement of  $\dot{M}_{O_2}$  and metabolic heat, the animals are in a fasted state. The duration of fasting has been shown to influence metabolic rate (Davies, 1966), so care must be taken to ensure that all animals are treated similarly.

#### Concluding remarks

We have constructed an inexpensive and sensitive calorimeter for the simultaneous measurement of metabolic heat and  $\dot{M}_{O_2}$  in fasted fish with a time resolution of 1–2 h, making it possible to measure metabolic rate in environments that compromise aerobic energy production. Combined with its low cost of construction and simple, modifiable design, this apparatus is obtainable to most researchers and has the potential to shed light on the metabolic responses of a broad range of species in any number of environments.

#### ACKNOWLEDGEMENTS

Special thanks to Bruce Gillespie in the University of British Columbia's Department of Zoology Machine Shop for his help with construction of the calorimeter, and to the anonymous reviewers for their insightful comments.

#### AUTHOR CONTRIBUTIONS

M.D.R., J.M.G. and J.G.R. co-designed the calorimeter. M.D.R. designed and carried out experiments. M.D.R. wrote the manuscript with editorial input from J.M.G. and J.G.R.

#### COMPETING INTERESTS

No competing interests declared.

#### FUNDING

This work was supported by a Natural Sciences and Engineering Research Council of Canada (NSERC) Discovery Grant to J.G.R. M.D.R. was supported by an NSERC postgraduate scholarship.

#### REFERENCES

- Addink, A. D. F., van den Thillart, G., Smit, H. and van Waversveld, J. (1991). A novel 1 liter flow-through calorimeter for heat production measurements on aquatic animals without stress. *Thermochim. Acta* **193**, 41–48.
- Brown, J. H., Gillooly, J. F., Allen, A. P., Savage, V. M. and West, G. B. (2004). Toward a metabolic theory of ecology. *Ecology* **85**, 1771–1789.

- Davies, P. M. C.** (1966). The energy relations of *Carassius auratus* L. II. The effect of food, crowding and darkness on heat production. *Comp. Biochem. Physiol.* **17**, 983-995.
- Fry, F. E. J., Black, V. S. and Black, E. C.** (1947). Influence of temperature on the asphyxiation of young goldfish (*Carassius auratus* L.) under various tensions of oxygen and carbon dioxide. *Biol. Bull.* **92**, 217-224.
- Hochachka, P. W. and Somero, G. N.** (2002). *Biochemical Adaptation: Mechanism and Process in Physiological Evolution*. Oxford: Oxford University Press.
- Kaiyala, K. J. and Ramsay, D. S.** (2011). Direct animal calorimetry, the underused gold standard for quantifying the fire of life. *Comp. Biochem. Physiol.* **158A**, 252-264.
- Mclean, J. and Tobin, G.** (1987). *Animal and Human Calorimetry*. Cambridge: Cambridge University Press.
- Mendelsohn, E.** (1964). *The Development of the Theory of Animal Heat*. Cambridge: Harvard University Press.
- Richards, J. G.** (2009). Metabolic and molecular responses of fish to hypoxia. In *Hypoxia: Fish Physiology*, Vol. 27 (ed. A. P. Farrell, J. G. Richards and C. J. Brauner), pp. 443-485. Academic Press.
- Stangl, P. and Wegener, G.** (1996). Calorimetric and biochemical studies on the effects of environmental hypoxia and chemicals on freshwater fish. *Thermochim. Acta* **271**, 101-113.
- Stevens, E. D. and Fry, F. E. J.** (1970). The rate of thermal exchange in a teleost, *Tilapia mossambica*. *Can. J. Zool.* **48**, 221-226.
- van Waversveld, J., Addink, A., van den Thillart, G. and Smit, H.** (1988). Direct calorimetry on free swimming goldfish at different oxygen levels. *J. Therm. Anal.* **33**, 1019-1026.
- van Waversveld, J., Addink, A. and van den Thillart, G.** (1989). Simultaneous direct and indirect calorimetry on normoxic and anoxic goldfish. *J. Exp. Biol.* **142**, 325-335.